

Deluxe Kit	008
Compliance Kit	007
Master Kit	006
Less Steel Kit	004
Overhaul Kit	002
Bushing Kit	030
Washer Kit	200
Bearing Kit	201
Technical Manual	400
Pump Part	507
Valve Body Parts	741
Case Parts	761

Note: Not all items are available for all transmissions

G

H

I

J

L3N/4N71B

NISSAN L3N71B - 3 SPEED E/L4N71B - 4 SPEED

MAZDA N4A-EL



53010



53010A



53010D

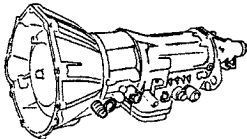

Rear Wheel Drive
4 Speed Illustrated

	L3N71B	3N71B
	3 SPEED w/L/U	3 SPEED w/o L/U
NISSAN	B110, 210, B210, 200SX, 240Z, 260Z, 280Z, 510, 610, 710, 810, Maxima (71-83), 620, 720, Pickups (71-85)	
MAZDA	616, 618, 626, 808, B2000, B2200, GLC, RX2, RX3, RX4, RX7, Cosmo, Rotary, Pickup - 74-87	
FORD	Courier - 73-76; Courier with external servo - 77-83; Granada with 250 6 cyl. with external servo. PLA-A 77-80	
	E/L4N71B	
	4 SPEED w/L/U & OVERDRIVE w/ & w/o TURBO	
NISSAN	200SX, 240SX, 300ZX, Pathfinder 2WD, Vans, Pickups - 2WD, 810, Maxima (84 only), Mini-Van - 86-Up	
MAZDA	All 2600 Series Pickups - 86-Up; MPV w/2.6L, Miata 91-97, RX7 84-88	
MITSUBISHI	Chrysler Plymouth Conquest-24 - 84-89, Starion - 83-87	
	N4A-EL	
	SPEED w/L/U & OVERDRIVE FULLY ELECTRIC	
MAZDA	RX7 - 89-Up; 929 - 88-Up; Miata - 3/89-92	



53010B



53010E

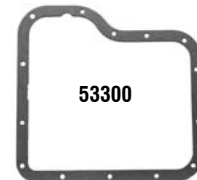

53300

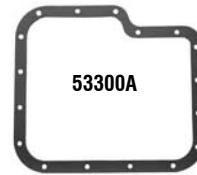

53300A

NOTE: This transmission, produced by JATCO was produced in various types. 3N71A & 3N71B are without lockup and have an inside or outside servo, 3 speeds. L3N71B is with lockup and an inside servo, 3 speeds. In 1983, E/L4N71B was produced with lockup, overdrive, 4 speeds; non-turbo & turbo charged engines. The Ford version is referred to as PLA-A and is 3 speed with external servo & has a 17 bolt pan.

ILL.	DESCRIPTION	QTY.	YEAR	PART NO.	REFERENCE NO.
COMPLIANCE KITS (CALIFORNIA KITS)					
007J	L3N71B (Combo Internal/External Servo)	1	71-87	53007F	CK4500A-R
007J	L4N71B, E4N71B.....	1	83-97	53007BF	CK4500B-R
MASTER OVERHAUL KITS (WITH STEELS)					
006J	L3N71B (Combo Internal/External Servo)	1	71-87	53006F	K4500A
006J	L4N71B, E4N71B.....	1	83-97	53006BF	K4500B
006J	N4A-EL.....	1	88-92	53006EF	K4500C
LESS STEEL KITS					
004J	L3N71B (Combo Internal/External Servo)	1	71-87	53004F	K4500A-LS
004J	L4N71B, E4N71B.....	1	83-97	53004BF	K4500B-LS
004J	N4A-EL.....	1	88-92	53004EF	K4500C-LS
OVERHAUL KITS (W/ RINGS & SEALS)					
002J	L3N71B (Combo Internal/External Servo)	1	71-87	53002F	K45900
002J	L4N71B, E4N71B.....	1	83-97	53002BF	K45900B
002J	N4A-EL.....	1	88-92	53002EF	K45900C
GASKET & SEAL KITS (W/O RINGS & SEALS)					
000J	L4N71B, E4N71B.....	1	83-97	53000BF	K45900B-1
000J	N4A-EL.....	1	88-92	53000EF	K45900C-1
FILTER KITS					
011J	L3N71B (Nissan)	1	71-87	53011	FK45800
011J	L3N71B (Ford).....	1	71-87	53011A	FK45800A
011J	L3N71B (Mazda B2600) 4wd.....	1	86-89	53011D	FK45800D
011J	L4N71B, E4N71B.....	1	83-97	53011B	FK45800B
011J	N4A-EL (10 Bolt) (Mazda 929 88-91, RX7 89-92).....	1	88-92	53011E	FK45800C

ILL.	DESCRIPTION	QTY.	YEAR	PART NO.	REFERENCE NO.
FILTERS					
010J	L3N71B (Nissan)	1	71-87	53010	45800
010J	L3N71B (Ford)	1	71-87	53010A	45800A
010J	L3N71B (Mazda B2600) 4wd	1	86-89	53010D	45800D
010J	L4N71B, E4N71B	1	83-97	53010B	45800B
010J	N4A-EL (10 Bolt) (Mazda 929 88-91, RX7 89-92)	1	88-92	53010E	45800C
BANDS					
Prefix Key: B = Borg Warner, A = OEM (Exc. BW), N = All Other New, R = Relined					
022B	Overdrive & Intermediate (Flex Type)	1-2	71-93	53022	45700A
022B	Overdrive & Intermediate (Hard Type)	1-2	71-93	53022H	45700
BUSHINGS					
030J	Bushing Kit, L3N71B	1	71-87	53030	K45901
030J	Bushing Kit, L4N71B, E4N71B, N4A-EL	1	83-93	53030B	K45901A
034A	Pump Body	1	71-93	53034	45005
036A	Stator Support (Front & Rear) (3 Speed)	2	71-93	53036	45007
044H	Stator Support (Front) (22.8mm OD) (4 Speed)	1	83-93	53044	45007A
044H	Stator Support (Center) (4 Speed)	1	83-93	53044A	45007B
044H	Stator Support (Rear) (23.0mm OD) (4 Speed)	1	83-93	53044C	45007C
038B	Overdrive Drum	1	83-93	53038	45006A
040G	Overdrive Sun Gear (31 T Sun Gear) (1.140" ID)	2	83-93	53040	45009A
040G	Overdrive Sun Gear (33 T Sun Gear) (1.220" ID)	1	83-93	53040A	45009B
043H	Overdrive Support To Overdrive Ring Gear (Front) (Large)	1	83-93	53043	N/A
046H	Direct Drum	1	71-93	53046	45006
052I	Forward Sun Gear	2	71-93	53052	45009
064E	Case (Front) (Narrow)	1-2	71-93	53064	45012
064E	Case (Rear) (Wide)	1	71-93	53064B	45008
066J	Extension Housing (1.375" ID) L3N71B	1	71-87	53066	45014
066J	Extension Housing (1.495" ID) L4N71B, E4N71B, N4A-EL	1	83-93	73066	45014B
METAL CLAD SEALS					
070A	Front	1	71-93	53070	45200A
074J	Rear, 1.375" ID (w/o Flange) L3N71B	1	71-87	53074	45201
074J	Rear, 1.375" ID (w/ Flange) L3N71B	1	71-87	53074A	45201A
074J	Rear, 1.495" ID (w/o Flange) L4N71B, E4N71B, N4A-EL	1	83-93	53074B	45201B
074J	Rear, 1.495" ID (w/ Flange) L4N71B, E4N71B, N4A-EL	1	83-93	53074C	45201C
074J	Rear, 1.495" ID (w/ Flange & Dust Boot) L4N71B, E4N71B, N4A-EL	1	83-93	53074D	N/A
074J	Adapter Housing 4wd (Mazda MPV Van)	1	83-93	73074C	45201D
FRICITION PLATES					
100B	Overdrive .063" (44 T)	2-4	83-93	53100	45103
106C	Forward & Direct .063" (44 T)	6-11	71-93	53100	45103
114D	Low & Reverse .078" (51 T)	4-8	71-93	53114	45102
STEEL PLATES					
120B	Overdrive .078" (28 T)	2	83-93	53120	45101
120B	Overdrive .063" (28 T)	2	87-93	18126	65101
120B	Overdrive .100" (28 T)	AR	71-93	53120EA	45101A
126C	Forward & Direct .078" (28 T)	6-10	71-93	53120	45101
126C	Forward & Direct .032" (28 T)	AR	71-93	53120A	N/A
126C	Forward & Direct .063" (28 T)	AR	71-93	18126	65101
134D	Low & Reverse .079" (13 T)	4-7	71-93	53134	45100

L3N/4N71B

ILL.	DESCRIPTION	QTY.	YEAR	PART NO.	REFERENCE NO.
MODULATORS					
160E	Modulator, Screw-In .840" Diaphragm.....	1	71-93	13160	45820A
160E	Modulator, Screw-In .910" Diaphragm.....	1	71-93	13160A	45820E
160E	Modulator, L4N71B (Mazda MPV Van).....	1	83-93	13160D	N/A
160E	Modulator, Push In (N4A-EL).....	1	88-93	53160A	45820G
VALVE BODY RECALIBRATION KITS					
165J	Shift Kit®, N4A-EL (Transgo®).....	1	88-93	T53165	K45908N
165J	Shift Correction Package, Accumulator Springs (Superior).....	1	83-93	A53926AK	N/A
SEALING RINGS					
175J	Ring Kit, L3N71B.....	1	71-93	53175	K45300
175J	Ring Kit, L4N71B, E4N71B.....	1	83-93	53175B	N/A
175J	Ring Kit, N4A-EL.....	1	88-93	53175C	N/A
THRUST WASHERS					
200J	Washer Kit, Selective Washers Only.....	1	71-93	53200A	N/A
211H	Direct Drum 1.70mm (.067").....	1	71-93	53211A	N/A
211H	Direct Drum 1.90mm (.075").....	1	71-93	53211B	45400
211H	Direct Drum 2.10mm (.083").....	1	71-93	53211C	N/A
211H	Direct Drum 2.30mm (.091").....	1	71-93	53211D	N/A
211H	Direct Drum 2.50mm (.098").....	1	71-93	53211E	N/A
214B	Overdrive Drum.....	1	83-93	53211B	45400
BEARINGS & RACES					
232E	Bearing w/ Race, Forward Drum To Hub.....	1	71-93	53232	N/A
GASKETS & O-RINGS					
300J	Gasket, Bottom Pan (Nissan) (Cork).....	1	71-93	53300	13100X
300J	Gasket, Bottom Pan (Nissan) (Fiber).....	1	71-93	53300F	13100F
300J	Gasket, Bottom Pan (Ford) (Cork).....	1	71-93	53300A	13100AX
300J	Gasket, Bottom Pan (Ford) (Fiber).....	1	71-93	53300AF	13100AF
305J	Gasket, Extension Housing.....	1	71-93	53305	13108
310A	Gasket, Front Pump (Non Lock-Up) L3N71B.....	1	71-87	53310	13101
310A	Gasket, Front Pump (Lock-Up) L3N71B.....	1-2	71-87	53310A	N/A
310A	Gasket, Pump To Overdrive Case.....	1	83-93	53310B	13101A
311A	O-Ring, Front Pump & Overdrive Case.....	1-2	71-93	53311	13102
TECHNICAL MANUALS					
400J	Tech Manual, L3N71B.....	1	71-87	53400	45Y01
400J	Tech Manual, L4N71B, E4N71B.....	1	83-93	53400B	45Y02
400J	Tech Manual, N4A-EL.....	1	88-93	53400C	45Y03
ELECTRICAL COMPONENTS					
420	Solenoid Assembly, N4A-EL (w/ 4 Solenoids).....	1	88-93	53420	31R-140
434E	Solenoid, Downshift 4N71B.....	1	83-93	53434	N/A
HARD PARTS					
Prefix Key: D = OEM, A = Aftermarket New, R = Remanufactured					
DRUMS & CLUTCH HUBS					
550B	Overdrive (Non Sprag Type) (3 Clutch).....	1	83-93	53550CA	N/A
550B	Overdrive (Non Sprag Type) (4 Clutch).....	1	83-93	53550C	45721C
550B	Overdrive (Sprag Type) (Bearing Type).....	1	83-93	53550B	45721E
550B	Overdrive (Sprag Type) (Washer Type).....	1	83-93	53550A	N/A

NISSAN RL3F01A - 3 SPEED

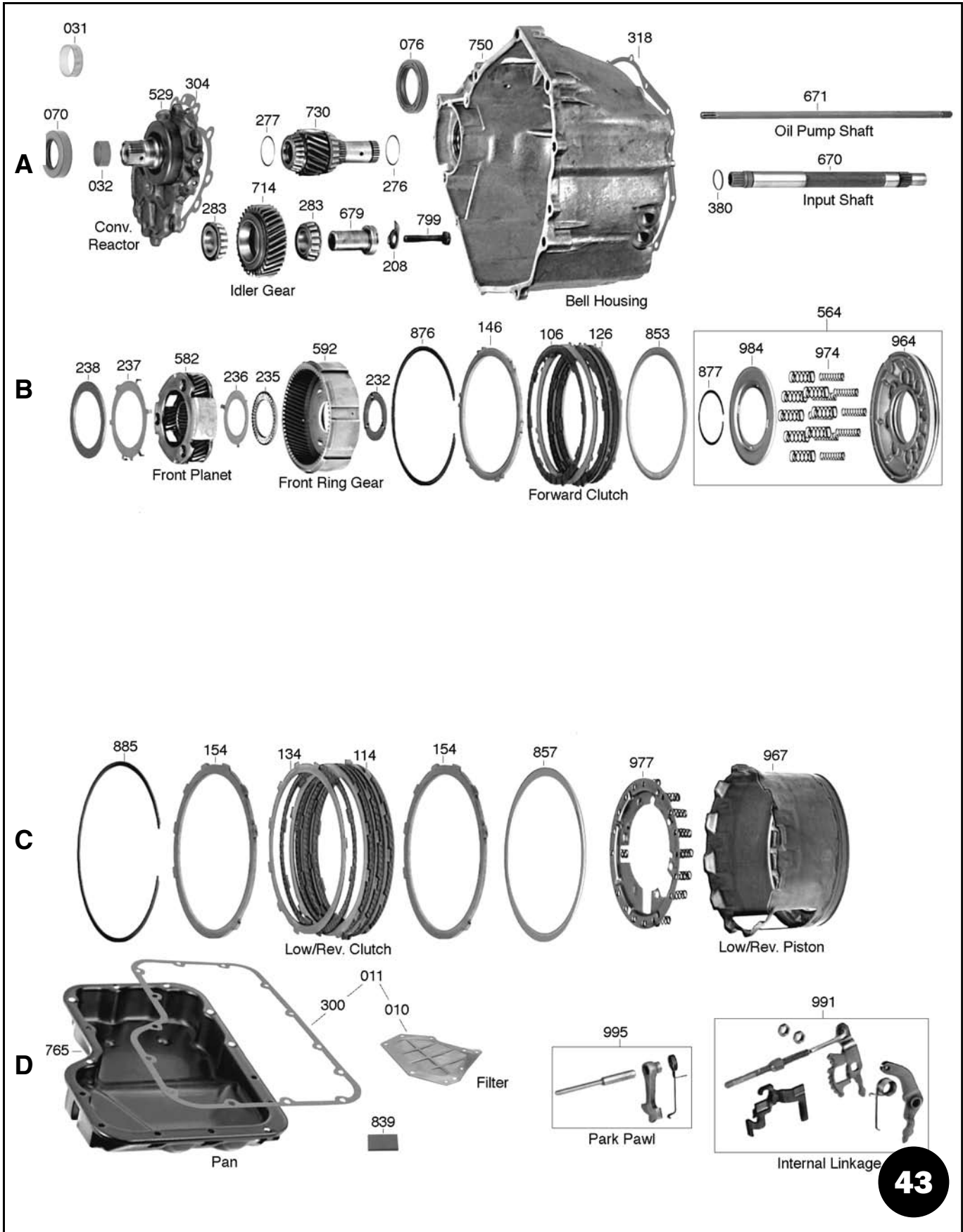

NISSAN RL3F01A - 3 SPEED

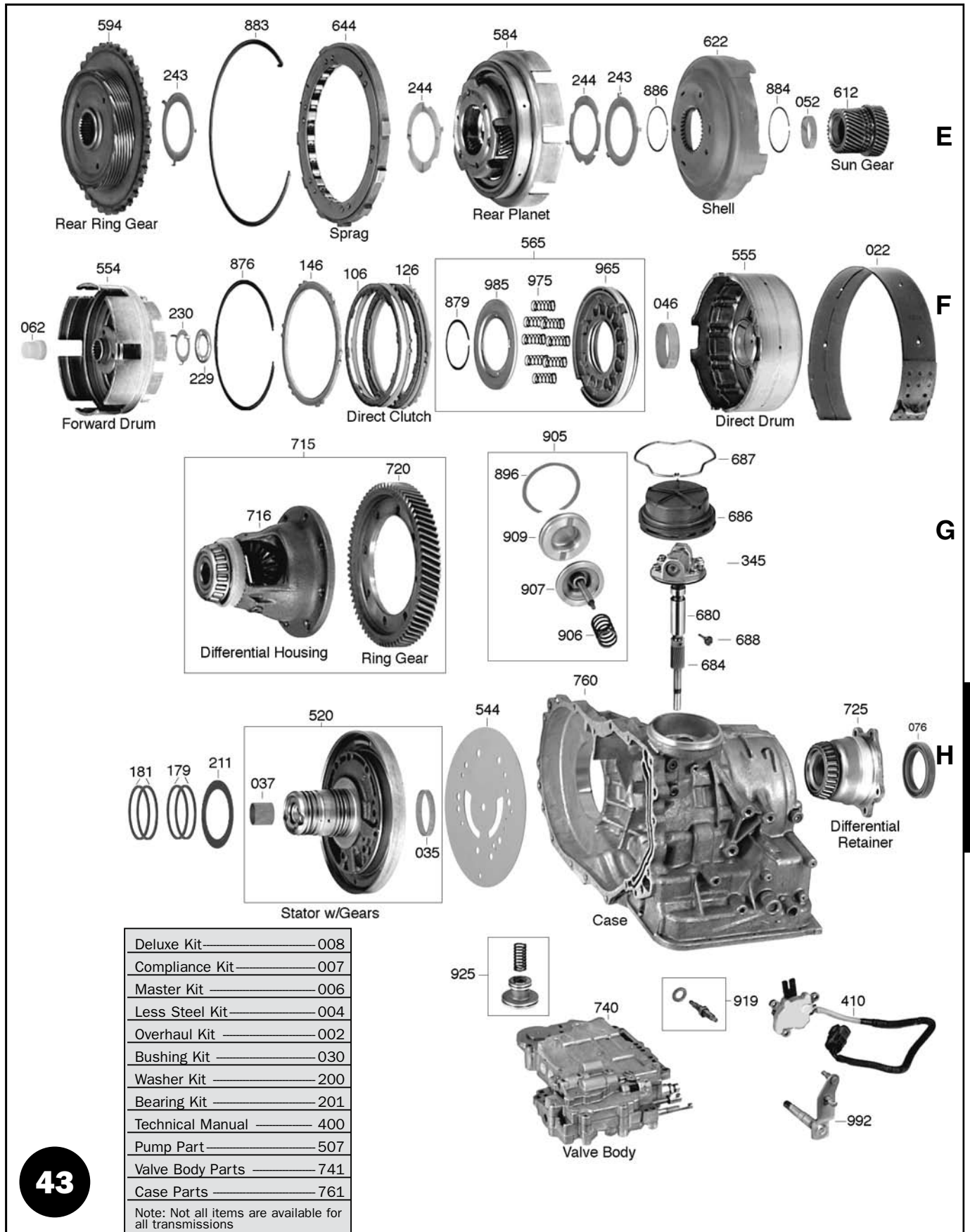

Deluxe Kit	008
Compliance Kit	007
Master Kit	006
Less Steel Kit	004
Overhaul Kit	002
Bushing Kit	030
Washer Kit	200
Bearing Kit	201
Technical Manual	400
Pump Part	507
Valve Body Parts	741
Case Parts	761

Note: Not all items are available for all transmissions

NISSAN

RL3F01A - 3 SPEED



43010



43010A



43300

ILL.	DESCRIPTION	QTY.	YEAR	PART NO.	REFERENCE NO.
COMPLIANCE KITS (CALIFORNIA KITS)					
007H	RN3F01A, RL3F01A (w/ .071" Fwd & Direct Frictions) (w/ 43010A)	1	87-92	43007BF	N/A
MASTER OVERHAUL KITS (WITH STEELS)					
006H	RN3F01A, RL3F01A (w/ .071" Fwd & Direct Frictions)	1	81-92	43006F	K6400
006H	RN3F01A, RL3F01A (w/ .063" Fwd & Direct Frictions)	1	81-92	43006AF	K6400
LESS STEEL KITS					
004H	RN3F01A, RL3F01A (w/ .071" Fwd & Direct Frictions)	1	81-92	43004F	K6400-LS
004H	RN3F01A, RL3F01A (w/ .063" Fwd & Direct Frictions)	1	81-92	43004AF	K6400-LS
OVERHAUL KITS (W/ RINGS & SEALS)					
002H	RN3F01A, RL3F01A.....	1	81-92	43002F	K64900
GASKET & SEAL KITS (W/O RINGS & SEALS)					
000H	RN3F01A, RL3F01A.....	1	81-92	43000F	K64900-1
FILTERS					
010D	RN3F01A, RL3F01A (1/4" Pick Up) (Shallow)	1	81-86	43010	64800
010D	RN3F01A, RL3F01A (3/4" Pick Up) (Deep)	1	87-92	43010A	64800B
FILTER KITS					
011D	RN3F01A, RL3F01A (1/4" Pick Up) (Shallow)	1	81-86	43011	FK64800
011D	RN3F01A, RL3F01A (3/4" Pick Up) (Deep)	1	87-92	43011A	FK64800B
BANDS					
Prefix Key: B = Borg Warner, A = OEM (Exc. BW), N = All Other New, R = Relined					
022F	Brake	1	81-92	43022	64700
BUSHINGS					
030H	Bushing Kit	1	81-92	43030	K64901
031A	Converter Hub.....	1	81-92	43031	64005
032A	Pump Housing	1	81-92	43032	64004
035H	Pump Gear.....	1	81-92	43035	64003
037H	Stator, Front	1	81-92	43036	64001
037H	Stator, Rear	1	81-92	43037	64002
046F	Front Drum	1	81-92	43046	64006
052E	Sun Gear.....	1	81-92	43052	64007
METAL CLAD SEALS					
070A	Front.....	1	81-92	43070	64200
076A	Axle (Both Sides)	2	81-92	43076	64203
078	Speed-O Gear Shaft	1	81-92	43078	64205
FRICTION PLATES					
106B	Forward & Direct (.071") (Non Turbo).....	6	81-92	43106	64100
106B	Forward & Direct (.061") (Turbo).....	7	81-92	43106A	64100A
114C	Low/ Reverse.....	3-5	81-92	43114	64106
STEEL PLATES					
126B	Forward & Direct (12 T)	5-7	81-92	43126	64101
126B	Forward & Direct (24 T)	AR	89-92	93126AA	68102B
134C	Low/ Reverse.....	3-5	81-92	43134	64107

NISSAN RL3F01A - 3 SPEED

ILL.	DESCRIPTION	QTY.	YEAR	PART NO.	REFERENCE NO.
SEALING RINGS					
175H	Ring Kit (Metal).....	1	81-92	43175	K64300
175H	Ring Kit (Teflon).....	1	81-92	43175T	K64300T
THRUST WASHERS & BEARINGS					
200H	Washer Kit (w/o Bearings).....	1	81-92	43200	N/A
200H	Washer Kit (w/ 3 Bearings).....	1	81-92	43200B	K64905
211H	Between Stator & Direct Drum (Black Plastic).....	1	81-92	43211	64401
232B	Hub to Forward Drum (Black Plastic) (No Tabs).....	1	81-92	43232	64402
230F	Race, Between Forward Drum & Stator.....	1	81-92	43230	64507
235B	Bearing, Between Front Planet & Ring Gear Hub.....	1	81-92	53232	N/A
GASKETS & O-RINGS					
300D	Gasket, Bottom Pan (Cork).....	1	81-92	43300	13120X
300D	Gasket, Bottom Pan (Fiber).....	1	81-92	43300F	13120F
304A	Gasket, Front Cover Gasket.....	1	81-92	43304	13115
318A	Gasket, Converter Housing to Case Gasket (Paper).....	1	81-92	43318	13116
318A	Gasket, Converter Housing to Case Gasket (Metal).....	1	81-92	43318B	13116M
318A	Gasket, Converter Housing to Case Gasket (Inner).....	1	81-92	43318A	N/A
325	Case Gasket Set (w/ 43304 & 43318).....	1	81-92	43325	N/A
326	Gasket, Filter.....	1	81-92	43326	N/A
TECHNICAL MANUALS					
400H	Tech Manual.....	1	81-92	43400	64Y01
HARD PARTS					
Prefix Key: D = OEM, A = Aftermarket New, R = Remanufactured					
PUMPS					
520H	Stator w/ Gears.....	1	81-92	43520	64910
DRUMS					
554F	Drum, Forward (4 Clutch).....	1	81-92	43554	64925
PLANETS					
582B	Front.....	1	81-92	43582	64930
584E	Rear.....	1	81-92	43584	N/A
594E	Ring Gear, Rear Planet.....	1	81-92	43594	64931
SUN GEARS, SHELLS & SUPPORTS					
612E	Sun Gear.....	1	81-92	43612	64927
622E	Shell (Hardened).....	1	81-92	43622	64926H
SPRAGS					
644E	Sprag Assembly, One Way Clutch w/ Race.....	1	81-92	43644	64918
MISCELLANEOUS COMPONENTS					
275	Axle Support Bearing.....	1	81-92	T43275	64731B
680G	Governor, Assembly (Gear Length 1 1/4").....	1	81-92	43680	64410
680G	Governor, Assembly (Gear Length 1 3/4").....	1	81-92	43680A	N/A
684G	Gear, Governor (1 1/4" Long).....	1	81-92	43684	64921
684G	Gear, Governor (1 3/4" Long).....	1	81-92	43684A	64921A
967C	Piston, Low/ Reverse Clutch.....	1	81-92	43967	64915

RL3F01A

NISSAN RE4F02A RL4F02A

**2WD, 4WD
FWD w/L/U**

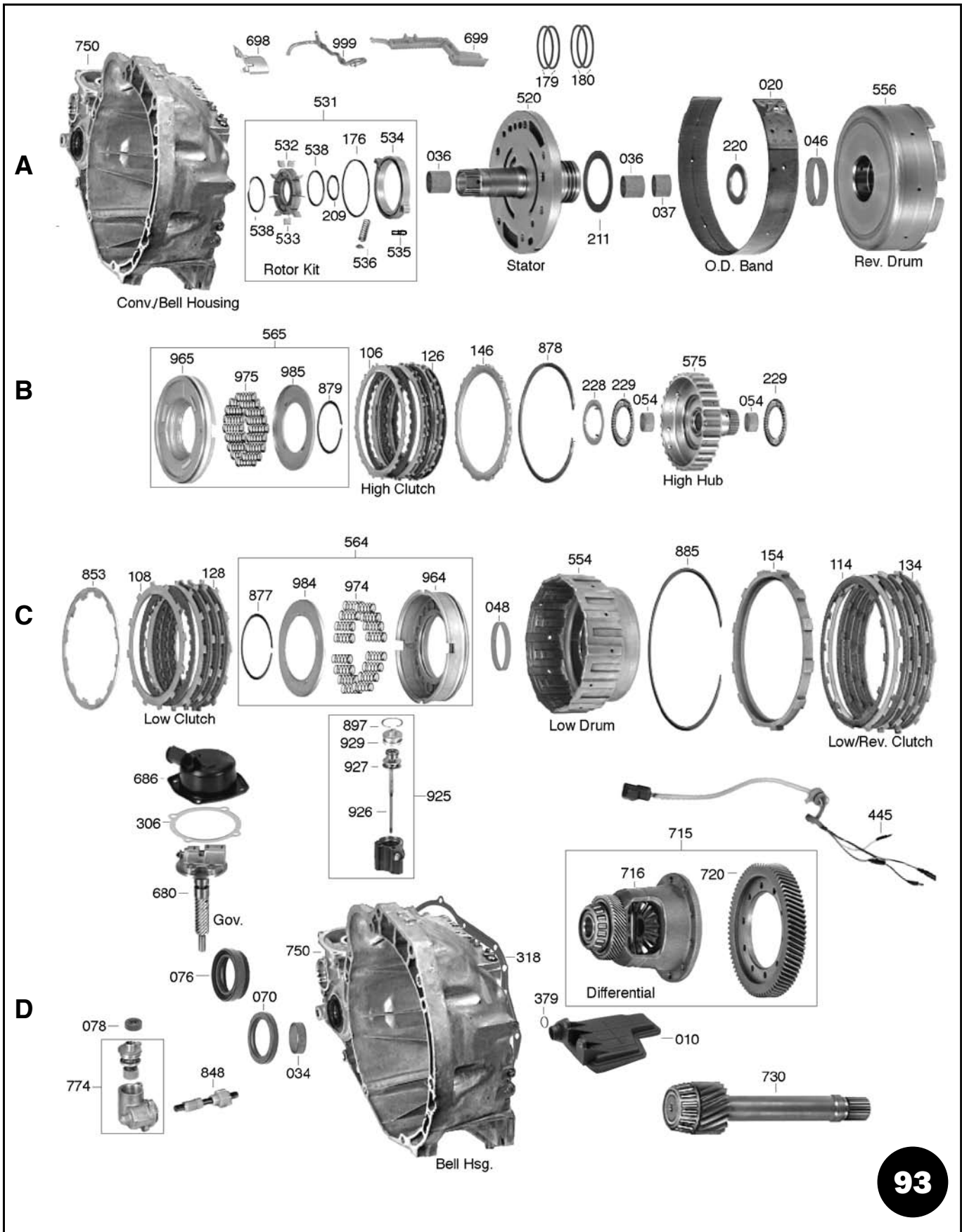

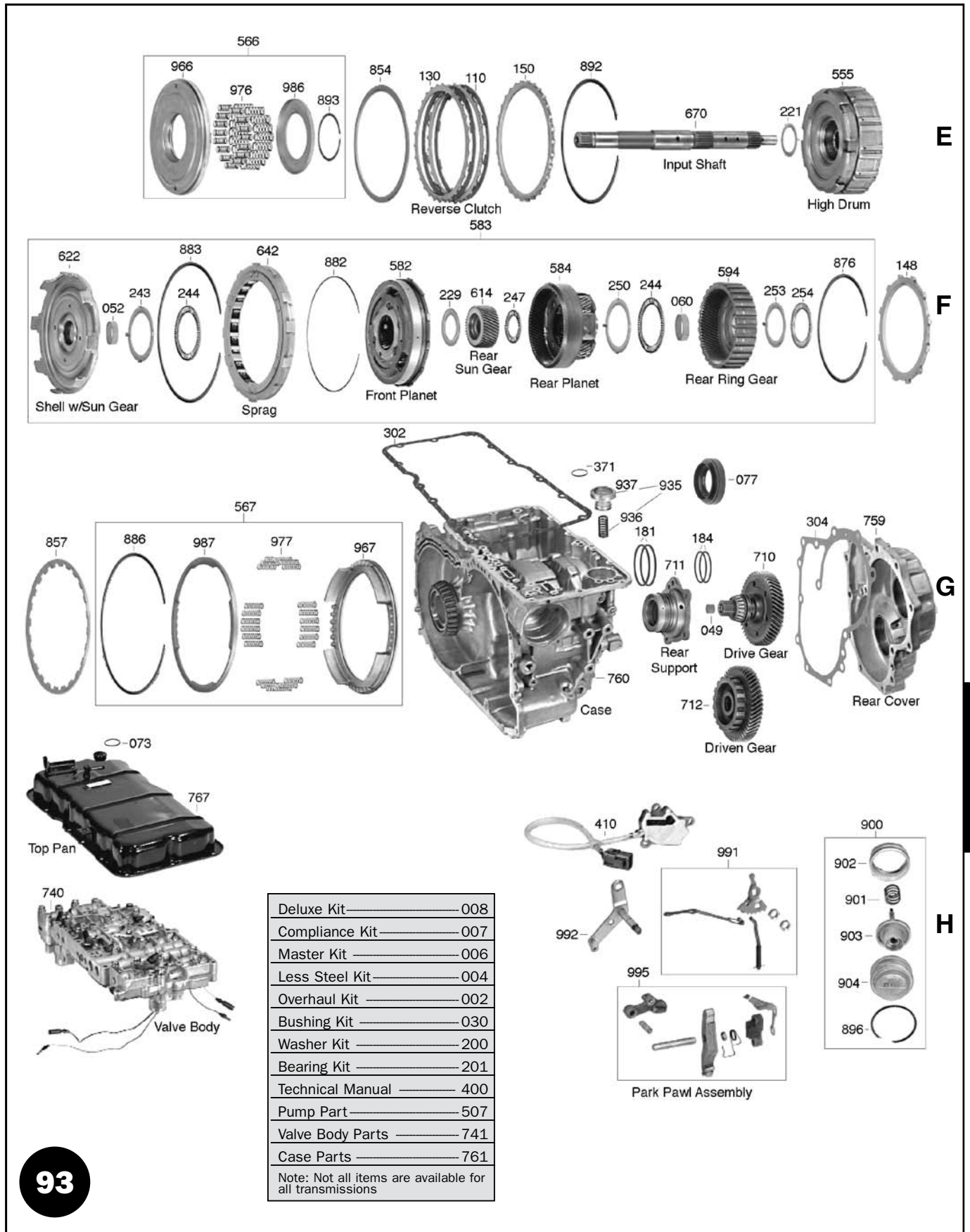

Deluxe Kit	008
Compliance Kit	007
Master Kit	006
Less Steel Kit	004
Overhaul Kit	002
Bushing Kit	030
Washer Kit	200
Bearing Kit	201
Technical Manual	400
Pump Part	507
Valve Body Parts	741
Case Parts	761
Note: Not all items are available for all transmissions	

NISSAN RE4F02A RL4F02A

2WD, 4WD FWD w/L/U



93010

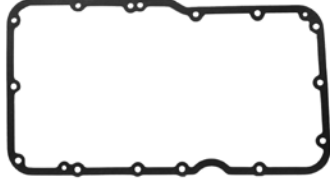

93302

RL4F02A		
Axxess - 2/4WD		89-Up
Maxima		7/84-7/88
Pulsar		8/87-9/89
Stanza, Stanza Station Wagon - 2/4WD		3/85-7/89
RE4F02A		
Maxima		8/88-Up
Stanza		7/89-Up

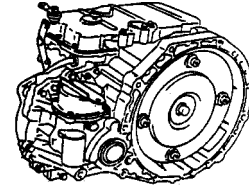

Front Wheel Drive

IMPORTANT NOTES

RL4F02A & RE4F02A do not have a bottom transmission oil pan. To service the filter, transmission disassembly is required. The RE4F02A is electronically shifted.

ILL.	DESCRIPTION	QTY.	YEAR	PART NO.	REFERENCE NO.
MASTER OVERHAUL KITS (WITH STEELS)					
006H	RL4F02A (Hydraulic) Maxima (8/85-88) (1)	1	85-88	93006F	K6800
006H	RL4F02A (Hydraulic) Stanza	1	86-89	93006AF	K6800A
006H	RL4F02A (Hydraulic) Pulsar	1	88-90	93006BF	K6800B
006H	RL4F02A (Hydraulic) Axxess, Pintara	1	90-93	93006DF	N/A
006H	RE4F02A (Electronic) Maxima	1	89-94	93006CF	K6800E
006H	RE4F02A (Electronic) Stanza	1	89-94	93006EF	K6800F
LESS STEEL KITS					
004H	RL4F02A (Hydraulic) Maxima (8/85-88) (1)	1	85-88	93004F	K6800-LS
004H	RL4F02A (Hydraulic) Stanza	1	86-89	93004AF	K6800A-LS
004H	RL4F02A (Hydraulic) Pulsar	1	88-90	93004BF	K6800B-LS
004H	RL4F02A (Hydraulic) Axxess, Pintara	1	90-93	93004DF	N/A
004H	RE4F02A (Electronic) Maxima	1	89-94	93004CF	K6800E-LS
004H	RE4F02A (Electronic) Stanza	1	89-94	93004EF	K6800F-LS
OVERHAUL KITS (W/ RINGS & SEALS)					
002H	RL4F02A (Hydraulic)	1	85-89	93002F	K68900
002H	RL4F02A (Hydraulic) Axxess, Pintara	1	90-93	93002HF	N/A
002H	RE4F02A (Electronic)	1	89-94	93002CF	K68900E
GASKET & SEAL KITS (W/O RINGS & SEALS)					
000H	RL4F02A (Hydraulic)	1	85-89	93000F	K68900-1
000H	RE4F02A (Electronic)	1	89-94	93000CF	N/A
<i>(1) To Service 7/84 to 7/85, order (4) 93106D Frictions & (6) 93126AC Steels.</i>					
FILTERS					
010D	RL4F02A, RE4F02A	1	84-94	93010	68800
BANDS					
Prefix Key: B = Borg Warner, A = OEM (Exc. BW), N = All Other New, R = Relined					
020A	Overdrive	1	84-94	93020	68700
BUSHINGS					
030H	Bushing Kit, RL4F02A, RE4F02A	1	84-94	93030	K68901
034D	Bell Housing	1	84-94	93034	68001
036A	Stator, Front (Non Lock-Up) (.948" OD)	1	84-94	93036	68002
036A	Stator, Front (Lock-Up) (1.030" OD)	1	84-94	93036A	N/A
036A	Stator, Center (1 Slot)	1	84-94	93036C	68003
037A	Stator, Rear (No Slots)	1	84-94	93037	68004
046A	Reverse Drum (2 Slots)	1	84-94	93046	68005
048C	Low Clutch Drum	1	84-94	93048	68009

ILL.	DESCRIPTION	QTY.	YEAR	PART NO.	REFERENCE NO.
BUSHINGS (Cont.)					
052F	Sun Gear.....	1	84-94	93052	68007
054B	High Clutch Hub (2 Required).....	2	84-94	73054	68006
060F	Rear Ring Gear.....	1	84-94	93060	68008
062	Output Shaft Pilot (.514" ID).....	1	84-94	93062	68010
METAL CLAD SEALS					
070D	Front (Converter Housing).....	1	84-94	93070	68200
073	Throttle Shaft.....	1	84-94	93073	68203
076D	Right Axle (33 x 59 x 17mm) (All 2wd).....	1	84-94	93076	68201
077G	Left Axle (39 x 57 x 17mm) (All Maximas).....	1	84-94	93077	68202
077G	Left Axle (39 x 57 x 17mm) (Stanza RL 2wd - Some).....	1	84-94	93077	68202
077G	Left Axle (39 x 57 x 21mm) (Stanza RL-SW 2wd - Some, Stanza RE 2wd, RL 4wd) ...	1	84-94	93077A	68204
077G	Left Axle (39 x 57 x 21mm) (Axxess RL 2wd, Pulsar RL).....	1	84-94	93077A	68204
077G	Left Axle (42 x 90 x 12mm) (Axxess RL 4wd).....	1	84-94	93077C	68204A
077G	Left Axle (46 x 90 x 11mm).....	1	84-94	93077B	82202A
078D	Speed-O Shaft.....	1	84-94	43078	64205
FRICTION PLATES					
106B	High (.062") (30 Wide T) 5.235" OD.....	4	84-94	93106B	68103B
106B	High (.062") (30 Wide T) 5.045" OD.....	4	84-94	93106A	68103
106B	High (.079") (30 Wide T) 5.045" OD.....	3	84-94	93106	68103A
108C	Low (30 T).....	4-6	84-94	93108	68104
110E	Reverse (8 T).....	2	85-89	93110	68100
110E	Reverse (34 T).....	2	90-94	93110A	68100A
114C	Low/ Reverse (12 T).....	5-7	84-94	93114	68106
STEEL PLATES					
126B	High (24 T) (.055").....	7	84-94	93126	68102E
126B	High (24 T) (.067").....	7	84-94	93126A	68102
126B	High (24 T) (.079").....	5	84-94	93126AA	68102B
126B	High (24 T) (.108").....	3	84-94	93126AB	N/A
126B	High (24 T) (.118").....	3	84-94	93126AC	N/A
126B	High (27 T) (.079").....	5	84-94	93126BA	68102C
126B	High (27 T) (.095").....	4	84-94	93126C	68102F
126B	High (27 T) (.118").....	3	84-94	93126B	68102A
128C	Low.....	5-7	84-94	93128	68105
130E	Reverse (30 Round T).....	2	84-94	93130	68101
130E	Reverse (30 Square T).....	2	84-94	93130A	68101A
134C	Low/ Reverse.....	5-7	84-94	93134	68107
VALVE BODY RECALIBRATION KITS					
165H	Shift Kit®, RE4F02A & RL4F02A (Transgo®).....	1	84-94	T93165	K68908E
SEALING RINGS					
175H	Ring Kit.....	1	84-94	93175	K68300
THRUST WASHERS					
200H	Washer Kit.....	1	84-94	93200C	N/A
211A	Stator to Reverse Drum .028" (Plastic).....	1	84-94	93211	N/A
211A	Stator to Reverse Drum .035" (Plastic).....	1	84-94	93211A	N/A
211A	Stator to Reverse Drum .043" (Plastic).....	1	84-94	93211B	N/A
211A	Stator to Reverse Drum .051" (Plastic).....	1	84-94	93211C	78400C
211A	Stator to Reverse Drum .067" (Plastic).....	1	84-94	93211E	N/A
211A	Stator to Reverse Drum .075" (Plastic).....	1	84-94	93211F	78400F

ILL.	DESCRIPTION	QTY.	YEAR	PART NO.	REFERENCE NO.
BEARINGS & RACES					
200H	Bearing Kit, Planetary (Partial)	1	84-94	93201	K68500S
221E	Race, Stator to High Drum .047" (Metal w/ 3 Outer Tabs)	1	84-94	93221AA	N/A
221E	Race, Stator to High Drum .055" (Metal w/ 3 Outer Tabs)	1	84-94	93221AB	78500C
221E	Race, Stator to High Drum .063" (Metal w/ 3 Outer Tabs)	1	84-94	93221AC	N/A
221E	Race, Stator to High Drum .079" (Metal w/ 3 Outer Tabs)	1	84-94	93221AE	78500F
228B	Race, High Drum to Hub (Metal w/ 3 Inner Tabs)	1	84-94	73228	78502
229B	Bearing w/ Race, High Drum to Hub (Both Sides) & Front Planet Rear	3	84-94	53232	N/A
243F	Race, Shell to Front Planet & Rear Planet to Ring Gear	2	84-94	73243	N/A
244F	Bearing w/ Race, Shell to Front Planet & Rear Planet to Ring Gear	2	84-94	73244	78505
253F	Race, Rear Ring Gear to Rear Support	1	84-94	93253	N/A
254F	Bearing, Rear Ring Gear to Rear Support	1	84-94	93254	68511
GASKETS & O-RINGS					
302G	Gasket, Top Pan Gasket (Cork)	1	84-94	93302	13818X
302G	Gasket, Top Pan Gasket (Fiber)	1	84-94	93302F	13818F
304H	Gasket, Transfer Gear Cover (Paper)	1	84-94	93304	13819
304H	Gasket, Transfer Gear Cover (Metal)	1	84-94	93304A	13819M
318D	Gasket, Bell Housing to Case (Paper)	1	84-94	93318	13821
318D	Gasket, Bell Housing to Case (Metal)	1	84-94	93318M	13821M
320	Gasket, Valve Body to Case	1	84-94	93320C	N/A
320	Gasket Set, Valve Body (Axxess, Pintara)	1	84-94	93320K	N/A
321	Gasket, Valve Body to Spacer Plate	1	84-94	93321C	N/A
322	Gasket, Valve Body (Lock-Up) (Upper)	1	84-94	93322CA	N/A
322	Gasket, Valve Body (Lock-Up) (Lower)	1	84-94	93322CB	N/A
362	O-Ring, Servo Cover	1	84-94	93362	N/A
TECHNICAL MANUALS					
400H	RL4F02A (Hydraulic)	1	84-94	93400A	68Y02
400H	RE4F02A (Electronic)	1	84-94	93400B	68Y03
ELECTRICAL COMPONENTS					
420	Solenoid Assembly (4 Solenoids w/ Mounting Plate)(RE4F02A)	1	89-94	93420	31A-127
425	Solenoid, Lock-Up (RL4F02A)	1	84-94	93425A	5A-184
425	Solenoid, Lock-Up (RE4F02A)	1	89-94	93425B	31A-127L
427	Solenoid, Overdrive (RL4F02A)	1	84-94	93427A	5A-183
445D	Repair Kit, External Wire Harness (7 Prong) (RE4F02A)	1	89-94	93445EAK	N/A
445D	Repair Kit, External Wire Harness (7 Plug-ins) (RE4F02A)	1	89-94	93445EK	N/A
HARD PARTS					
Prefix Key: D = OEM, A = Aftermarket New, R = Remanufactured					
PUMPS					
520A	Stator, (3" Shaft) (Stepped)	1	84-94	93520B	68922
520A	Stator, (3 1/4" Shaft) (Stepped)	1	84-94	93520CA	68922B
531A	Rotor Kit, Pump (w/ Vanes, Slide & Rotor)	1	84-94	93531	N/A
DRUMS & CLUTCH HUBS					
555E	High (24 T Steels)	1	84-94	93555A	68925A
555E	High (27 T Steels)	1	84-94	93555	68925
556A	Reverse (Cast Iron, Most Maxima's)	1	84-94	93556	68928
556A	Reverse (Steel, Most Stanza's)	1	84-94	93556A	68928A
575B	Clutch Hub, High Clutch (Cast Iron Clutch Hub)	1	84-94	93575A	68930

ILL.	DESCRIPTION	QTY.	YEAR	PART NO.	REFERENCE NO.
PLANETS					
582F	Front (Flat Where Low Drum Sets) (1 Groove)	1	84-94	93582C	N/A
582F	Front (Half Moon Cuts Where Low Drum Sets) (1 Groove)	1	84-94	93582B	N/A
583F	Planet Kit, (Half Moon Cuts on Front Planet Where Low Drum Rides)	1	84-94	93583	K68980A
583F	Planet Kit, (Flat on Front Planet Where Low Drum Rides)	1	84-94	93583A	K68980C
SUN GEARS, SHELLS & SUPPORTS					
614F	Sun Gear, Rear (No Groove)	1	84-94	93614	68985
614F	Sun Gear, Rear (1 Groove)	1	84-94	93614A	N/A
622F	Shell, w/ Sun Gear (No Grooves)	1	84-94	93622	68981
622F	Shell, w/ Sun Gear (1 Groove)	1	84-94	93622A	N/A
SPRAGS					
642F	Sprag Assembly, One Way Clutch w/ Race	1	84-94	93642	68918
VALVE BODIES					
740H	Valve Body (Premium) Hydraulic	1	84-94	93740-3	P68990
740H	Valve Body (Premium) Electronic	1	88-94	93740-1	P68990E
741H	Sleeve, Boost Valve (Pressure Regulator)	1	84-94	93741P-2	68971
BELLHOUSINGS					
750A	Bell Housing, Square Starter Hole (RL4F02A) (LDTA Code)	1	84-94	93750B	68920B
750A	Bell Housing, Square Starter Hole (RE4F02A) (VG Code)	1	84-94	93750BB	68920
750A	Bell Housing (CA Code)	1	85-94	93750AB	68920A
MISCELLANEOUS COMPONENTS					
854E	Reverse Cushion Kit (Cast Drum Saver Kit)	1	84-94	93854K	K68101
854E	Reverse Cushion Kit (Steel Drum Saver Kit)	1	84-94	73854K	K78101B
854E	Reverse Cushion Plate w/ Tangs	1	84-94	93854A	68950A
NOTES					

RE4F02A

NISSAN RE4F03A/RL4F03A

FWD - 4 SPEED

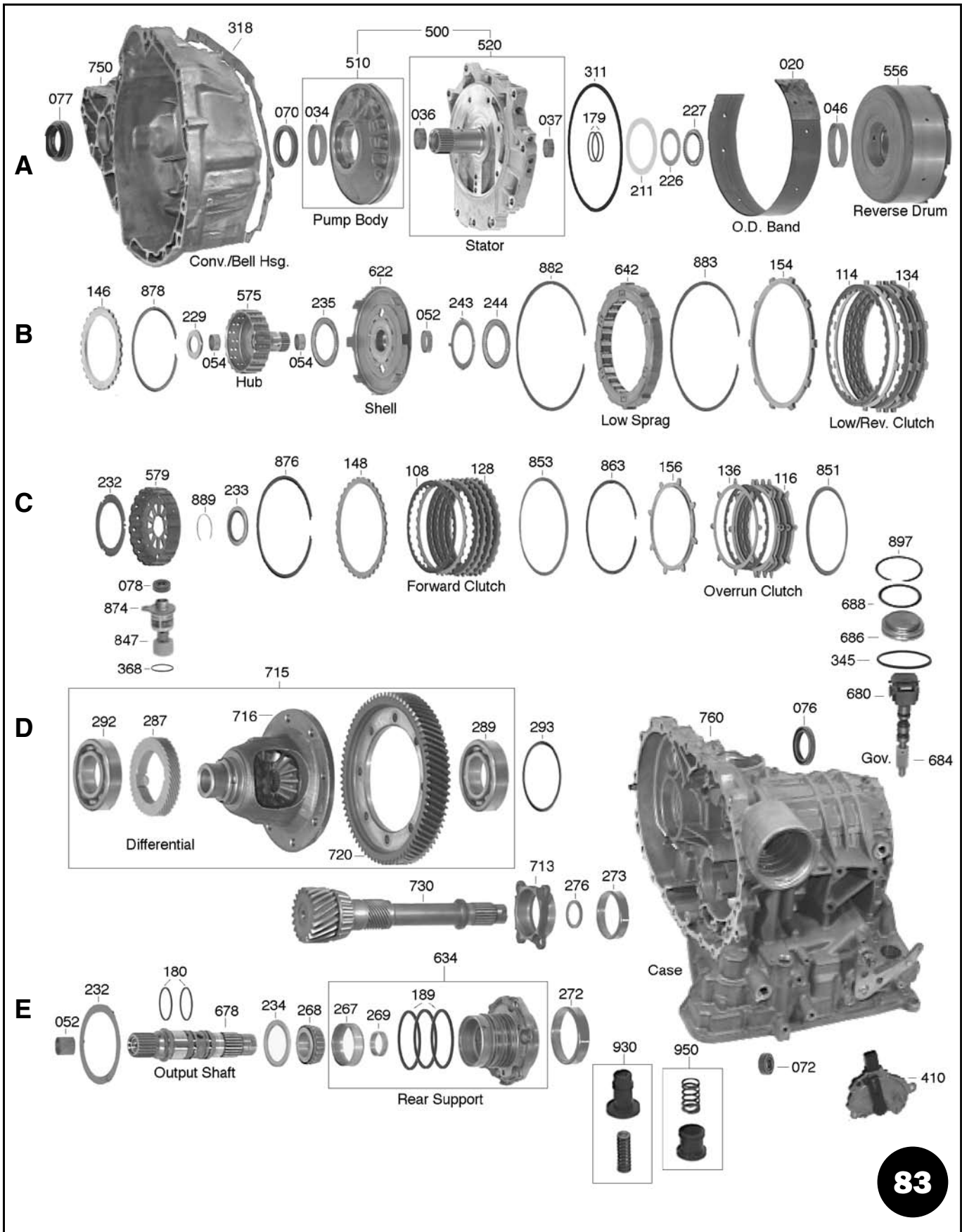

NISSAN RE4F03A/RL4F03A FWD - 4 SPEED

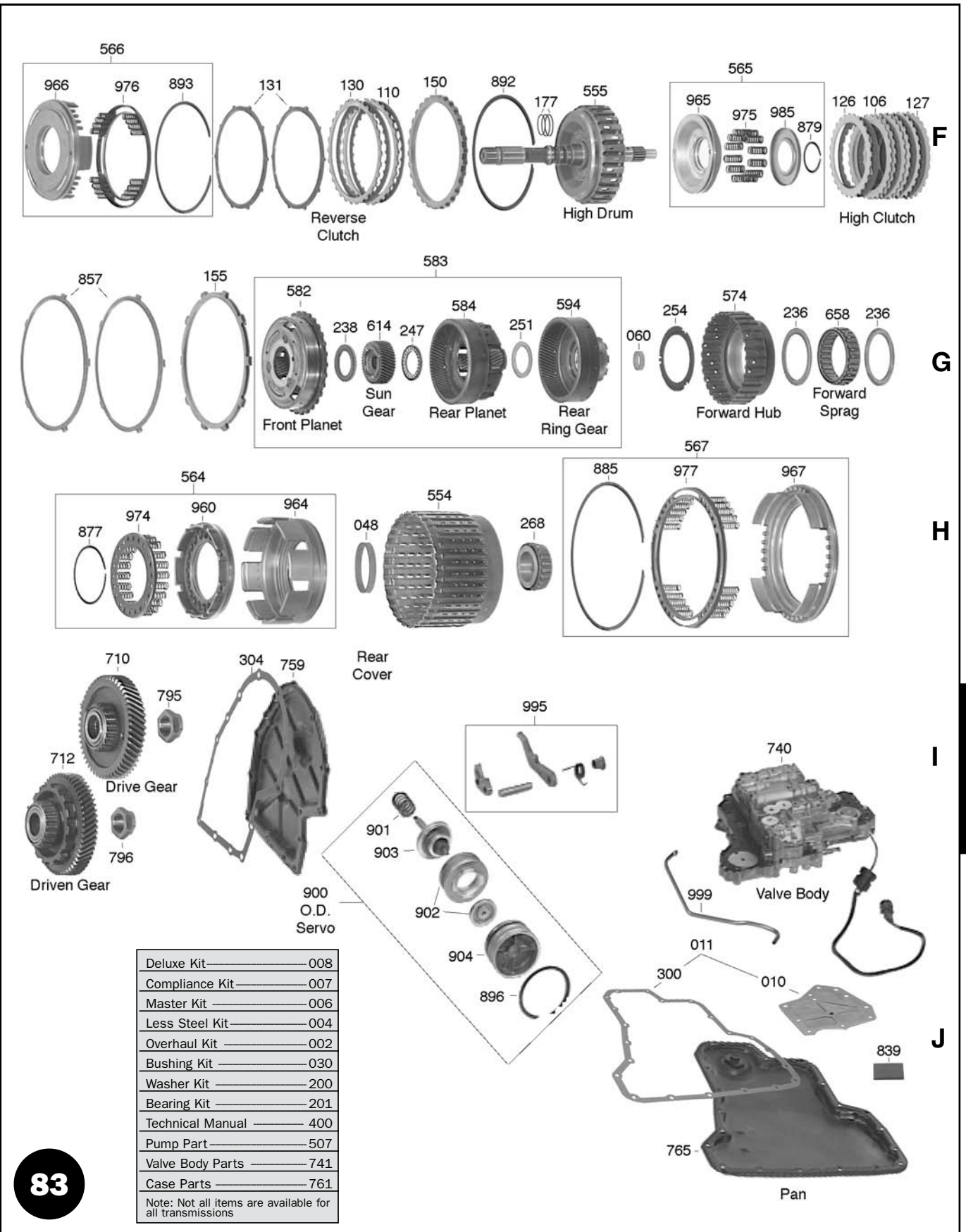

Deluxe Kit	008
Compliance Kit	007
Master Kit	006
Less Steel Kit	004
Overhaul Kit	002
Bushing Kit	030
Washer Kit	200
Bearing Kit	201
Technical Manual	400
Pump Part	507
Valve Body Parts	741
Case Parts	761

Note: Not all items are available for all transmissions

NISSAN RE4F03A/RL4F03A FWD - 4 SPEED



83010AA



83300A

ILL.	DESCRIPTION	QTY.	YEAR	PART NO.	REFERENCE NO.
MASTER OVERHAUL KITS (WITH STEELS)					
006J	RL4F03A, RE4F03A, RE4F03B, RE4F03V (1.6L)	1	91-97	83006AF	K8200A
006J	RL4F03A, RE4F03A, RE4F03B, RE4F03V (1.6L)	1	98-Up	83006DF	K8200D
006J	RL4F03A, RE4F03A, RE4F03B, RE4F03V (2.0L)	1	91-97	83006CF	N/A
006J	RL4F03A, RE4F03A, RE4F03B, RE4F03V (2.0L)	1	98-Up	83006EF	N/A
006J	RE4F03A (Micra)	1	04-Up	83006H	K8200K
LESS STEEL KITS					
004J	RL4F03A, RE4F03A, RE4F03B, RE4F03V	1	91-97	83004AF	K8200A-LS
004J	RL4F03A, RE4F03A, RE4F03B, RE4F03V	1	98-Up	83004DF	K8200D-LS
004J	RE4F03A (Micra)	1	04-Up	83004H	K8200K-LS
OVERHAUL KITS (W/ RINGS & SEALS)					
002J	RL4F03A, RE4F03A, RE4F03B, RE4F03V	1	91-Up	83002AF	K82900A
002J	RE4F03A (Micra)	1	04-Up	83002H	K82900K
FILTER KITS					
011J	RL4F03A, RE4F03A, RE4F03B, RE4F03V	1	91-Up	83011AA	FK82800A
FILTERS					
010J	RL4F03A, RE4F03A, RE4F03B, RE4F03V	1	91-Up	83010AA	82800A
BANDS					
Prefix Key: B = Borg Warner, A = OEM (Exc. BW), N = All Other New, R = Relined					
020A	Overdrive (RL4F03A, RE4F03A) (w/o Tab)	1	91-Up	83020A	82700A
020A	Overdrive (RL4F03A, RE4F03A) (w/ Tab)	1	00-Up	83020AA	82700C
020A	Overdrive (RE4F04A, RE4F04B)	1	00-Up	83020B	82700B
BUSHINGS					
030J	Bushing Kit	1	91-Up	83030A	K82901A
034A	Pump Housing	1	91-Up	83034A	82001A
METAL CLAD SEALS					
070A	Converter Housing	1	91-Up	83070A	82200
072E	Manual Lever	1	91-Up	60072	50203
077A	Left Axle (w/o Viscous Coupling)	1	91-Up	83076AA	82202B
077A	Left Axle (w/ Viscous Coupling)	1	91-Up	83077AA	82202C
076D	Right Axle (1.6L Engine)	1	91-Up	83076AA	82202B
076D	Right Axle (2.0L Engine)	1	91-Up	83076A	82202D
078	Speed-O-Gear Shaft	1	91-Up	83078A	45205A
FRICTION PLATES					
106F	High .063" (.265" Wide T) (Exc. 1.6L)	4	91-Up	83106AB	82103C
106F	High .079" (.170" Wide T) (1.6L)	4	91-Up	83106AA	82103B
108C	Forward	5	91-Up	83108A	82104A
110F	Reverse	2	91-Up	83110A	82100A
114B	Low/ Reverse (5.89" OD)	5	91-97	83114A	82106A
114B	Low/ Reverse (5.94" OD)	5	98-Up	83114AA	82106C
116C	Overrun	3	91-Up	83116A	82108A
STEEL PLATES					
126F	High (.059")	6	91-Up	83126AA	82102E
126F	High (.079")	5	91-Up	83126A	82102D
128C	Forward	5	91-Up	83128A	82105A

NISSAN RE4F03A/RL4F03A FWD - 4 SPEED

ILL.	DESCRIPTION	QTY.	YEAR	PART NO.	REFERENCE NO.
STEEL PLATES (Cont.)					
130F	Reverse	2	91-Up	83130A	82101A
134B	Low/ Reverse.....	5	91-Up	83134A	82107A
136C	Overrun	5	91-Up	83136A	82109A
VALVE BODY RECALIBRATION KITS					
165J	Shift Kit®, RL4F03A (Transgo®).....	1	91-Up	T83165A	K82908D
165J	Shift Kit®, RE4F03A (Transgo®)	1	93-Up	T83165D	K82908A
165J	Shift Kit®, RE4F03B (Transgo®).....	1	00-Up	T83165E	K82908F
165J	Reprogramming Kit™, RL4F03A (Transgo®)	1	91-Up	T83169A	RL4F03A-HD2
165J	Reprogramming Kit™, RE4F03A (Transgo®).....	1	93-Up	T83169D	RE4F03A-HD2
165J	Reprogramming Kit™, RE4F03B (Transgo®).....	1	00-Up	T83169E	RE4F03B-HD2
SEALING RINGS					
175J	Ring Kit.....	1	91-Up	83175A	K82300A
THRUST WASHERS					
211A	Washer Kit, RL4F03A/RE4F03A Stator Selectives Only (6 Pieces)	1	91-Up	83211AAK	N/A
GASKETS & O-RINGS					
300J	Gasket, Bottom Pan (Cork).....	1	91-Up	83300A	13973X
300J	Gasket, Bottom Pan (Fiber).....	1	91-Up	83300AF	13973F
304I	Gasket, Side Cover.....	1	91-Up	83304A	N/A
311A	O-Ring, Pump to Case.....	1	91-Up	83311A	13989
TECHNICAL MANUALS					
400J	Tech Manual	1	91-Up	83400A	82Y02
ELECTRICAL COMPONENTS					
420	Solenoid Assembly (1.6L) (2 Solenoids).....	1	91-94	83420AC	5A-168
420	Solenoid Assembly (1.6L) (2 Solenoids).....	1	95-Up	83420AG	5A-169
420	Solenoid Assembly (2.0L) (2 Solenoids).....	1	91-92	83420AC	5A-168
420	Solenoid Assembly (2.0L) (5 Solenoids) (Long Wire).....	1	93-98	83420AE	31A-131
420	Solenoid Assembly (2.0L & 1.8L) (5 Solenoids) (Short Wire)	1	99-Up	83420AF	31A-131A
HARD PARTS					
Prefix Key: D = OEM, A = Aftermarket New, R = Remanufactured					
500A	Pump Complete	1	91-Up	83500A	82920B
554H	Drum, Forward & Overrun	1	91-Up	83554A	82929B
555F	Drum, High w/ 5 3/8" Input Shaft (From Drum to Converter End)	1	91-Up	85555AA	82925E
555F	Drum, High w/ 5 3/16" Input Shaft (From Drum to Converter End)	1	91-Up	83555AB	82925B
556A	Drum, Reverse.....	1	91-Up	83556A	82923B
642B	Sprag , Low Clutch (15 Rollers)	1	91-Up	83642A	82960B
642B	Sprag , Low Clutch (19 Elements).....	1	91-Up	83642AB	82960A
658G	Sprag , Forward (24 Lug, .387" Wide Lugs)	1	91-Up	83658AA	82940C
658G	Sprag , Forward (24 Lug, .465" Wide Lugs)	1	91-Up	83658AB	82940A
680D	Governor, Assembly (16 T)	1	91-Up	83680A	N/A
684D	Governor Gear (16 T)	1	91-Up	83684A	82921
686D	Cover, Governor (Tin)	1	91-Up	83686A	N/A
740I	Valve Body (2 Solenoid) RL4F03A	1	91-Up	83740AA	82990B
740I	Valve Body (5 Solenoid) RE4R03A	1	91-Up	83740AB	82990E

RE4F03A

RE4F04A, RE4F04B JF403E, LJ4A-EL

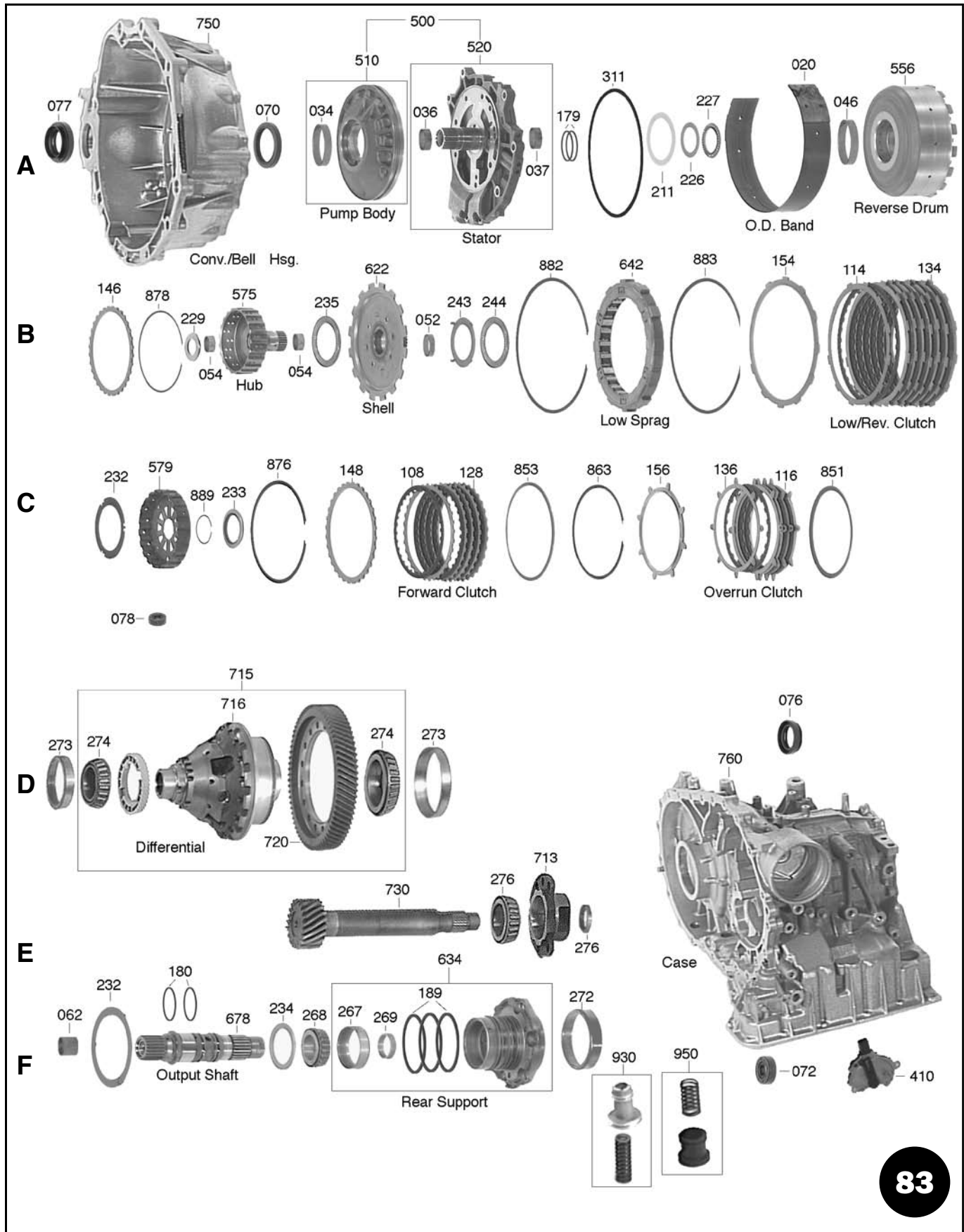

RE4F04A, RE4F04B JF403E, LJ4A-EL

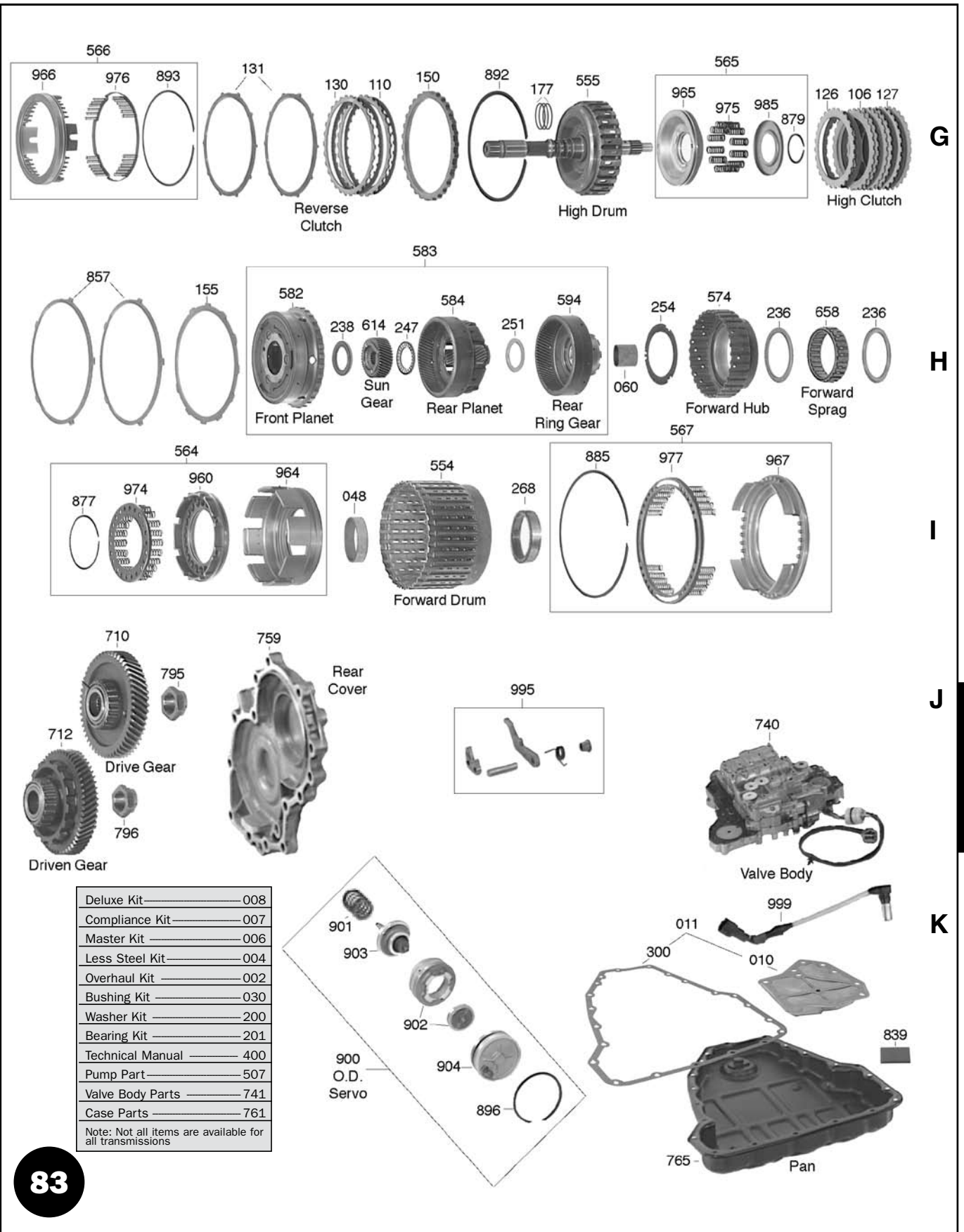

RE4F04A, RE4F04B JF403E, LJ4A-EL



83010AE



83010AG



83010BB



83010BC



83300B

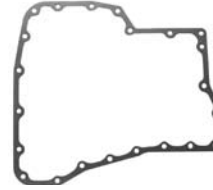

83300C

83300D

ILL.	DESCRIPTION	QTY.	YEAR	PART NO.	REFERENCE NO.
MASTER OVERHAUL KITS (WITH STEELS)					
006K	JF403E (GEO, Isuzu)	1	90-93	83006AAF	K8200
006K	LJ4A-EL (Mazda)	1	95-Up	83006ABF	K8200C
006K	RE4F04A, RE4F04B, 4F20E (Nissan, Ford, Infiniti) (Exc 3.5L)	1	92-Up	83006BF	K8200B
006K	RE4F04A, RE4F04B, 4F20E (Nissan, Ford, Infiniti) (3.5L)	1	92-Up	83006GF	N/A
LESS STEEL KITS					
004K	JF403E (GEO, Isuzu)	1	90-93	83004AAF	K8200-LS
004K	LJ4A-EL (Mazda)	1	95-Up	83004ABF	K8200C-LS
004K	RE4F04A, RE4F04B, 4F20E (Nissan, Ford, Infiniti) (Exc 3.5L)	1	92-Up	83004BF	K8200B-LS
004K	RE4F04A, RE4F04B, 4F20E (Nissan, Ford, Infiniti) (3.5L)	1	92-Up	83004GF	N/A
OVERHAUL KITS (W/ RINGS & SEALS)					
002K	JF403E, LJ4A-EL (Mazda, GEO, Isuzu)	1	90-Up	83002AAF	K82900
002K	RE4F04A, RE4F04B, 4F20E (Nissan, Ford, Infiniti)	1	92-Up	83002BF	K82900B
FILTER KITS					
011K	JF403E (GEO, Isuzu)	1	90-93	83011AE	FK82800
011K	LJ4A-EL (Mazda)	1	95-Up	83011AG	FK82800C
011K	RE4F04A, RE4F04B, 4F20E (0.400" Pickup Tube) (Nissan, Ford, Infiniti)	1	92-Up	83011BB	FK82800B
011K	RE4F04A, RE4F04B, 4F20E (1.300" Pickup Tube) (Nissan)	1	02-Up	83011BC	FK82800D
FILTERS					
010K	JF403E (GEO, Isuzu)	1	90-93	83010AE	82800
010K	LJ4A-EL (Mazda)	1	95-Up	83010AG	82800C
010K	RE4F04A, RE4F04B, 4F20E (0.400" Pickup Tube) (Nissan, Ford, Infiniti)	1	92-Up	83010BB	82800B
010K	RE4F04A, RE4F04B, 4F20E (1.300" Pickup Tube) (Nissan)	1	02-Up	83010BC	82800D
BANDS					
Prefix Key: B = Borg Warner, A = OEM (Exc. BW), N = All Other New, R = Relined					
020A	Overdrive (1 9/16" Wide) (JF403E, LJ4A-EL)	1	90-Up	83020C	82700
020A	Overdrive (1 5/8" Wide) (RE4F04A, RE4F04B, 4F20E)	1	92-Up	83020B	82700B
BUSHINGS					
030K	Bushing Kit (RE4F04A)	1	90-Up	83030B	K82901B
034A	Pump Housing	1	90-Up	83034B	82001B
METAL CLAD SEALS					
070A	Front (JF403E, LJ4A-EL)	1	90-Up	98070	82200
070A	Front (RE4F04A, RE4F04B, 4F20E)	1	92-Up	83070B	82200A
076D	Axle (Both Sides) (JF403E)	2	90-Up	83076C	65201A
076D	Axle (Both Sides) (LJ4A-EL)	2	90-Up	42076A	65201
077A	Left Axle (RE4F04A, RE4F04B, 4F20E) (w/o Viscous Coupling)	1	92-Up	83077B	82202
077A	Left Axle (RE4F04V) (w/ Viscous Coupling)	1	92-Up	83077BA	82202A
076D	Right Axle (RE4F04A, RE4F04B, 4F20E)	1	92-Up	93076	68201

RE4F04A, RE4F04B JF403E, LJ4A-EL

ILL.	DESCRIPTION	QTY.	YEAR	PART NO.	REFERENCE NO.
FRICTION PLATES					
106G	High (20 T) (JF403E)	4	90-93	83106BB	82103
106G	High (21 T) (Exc. JF403E).....	4	92-5/94	83106B	82103A
106G	High (24 T) (.063") (Exc. 3.5L).....	4	6/94-Up	83106BA	82103D
106G	High (24 T) (.059") (3.5L).....	4	02-Up	83106BC	82103F
108C	Forward .055" (32 T) (LJ4A-EL).....	6	95-Up	83108BB	82104B
108C	Forward .063" (32 T) (Exc. LJ4A-EL)	4	90-Up	83108B	82104
110G	Reverse (5.500"OD) (Exc 3.5L).....	2	90-Up	83110B	82100
110G	Reverse (5.799"OD) (3.5L)	2	02-Up	83110BA	82100D
114B	Low/ Reverse .063" (32 T) (JF403E, LJ4A-EL)	7	90-Up	83114B	82106
114B	Low/ Reverse .071" (32 T) (RE4F04A, RE4F04B, 4F20E)	6-7	92-Up	83114BA	82106B
116C	Overrun .063" (20 T)	3	90-Up	83116B	82108
STEEL PLATES					
126G	High (.055", 3.615" ID) (Exc. JF403E).....	6	92-Up	83126BA	82102C
126G	High (.079", 3.615" ID) (Exc. JF403E).....	1	92-Up	83126BB	82102B
126G	High (.079", 4.686" ID) (JF403E)	6	90-93	83126BD	82102A
126G	High (.087", 4.686" ID) (JF403E).....	6	90-93	83126BC	82102
128C	Forward (.071") (Exc. LJ4A-EL)	6	90-Up	83128B	82105
128C	Forward (.055") (L4JA-EL).....	6	95-Up	83128BB	82105B
130G	Reverse (5.756" OD) (30 T) (Exc 3.5L)	2-3	90-Up	83130B	82101
130G	Reverse (5.984" OD) (32 T) (3.5L).....	2-3	02-Up	83130BA	82101D
134B	Low/ Reverse (10 Narrow T) (Exc. JF403E).....	6-8	92-Up	83134B	82107B
134B	Low/ Reverse (10 Wide T) (JF403E).....	6	90-93	83134C	82107
136C	Overrun	3-5	90-Up	83136B	82109
PRESSURE PLATES					
Prefix Key: D = OEM, A = Aftermarket New, R = Remanufactured					
146G	High (.134", 3.615" ID) Top	1	90-Up	83146BC	63131B
VALVE BODY RECALIBRATION KITS					
165K	Shift Kit® (RE4F04A, RE4F04B, 4F20E) (Transgo®).....	1	92-Up	T83165B	K82908B
165K	Shift Kit® (RE4F04B) (Transgo®).....	1	00-Up	T83165C	K82908G
165K	Shift Kit® (LJ4A-EL) (Transgo®)	1	95-Up	T83165F	K82908C
165K	Reprogramming Kit™ (RE4F04A, RE4F04B, 4F20E) (Transgo®).....	1	92-Up	T83169B	RE4F04A-HD2
165K	Reprogramming Kit™ (RE4F04B) (Transgo®).....	1	00-Up	T83169C	RE4F04B-HD2
165K	Reprogramming Kit™ (JF403E, LJ4A-EL) (Transgo®)	1	95-Up	T83169F	LJ4AEL-HD2
SEALING RINGS					
175K	Ring Kit (RE4F04A, RE4F04B, 4F20E)	1	92-Up	83175B	K82300
175K	Ring Kit (JF403E, LJ4A-EL).....	1	90-Up	83175C	K82300
GASKETS & O-RINGS					
300K	Gasket, Bottom Pan (21 Bolts) (RE4F04A, RE4F04B, 4F20E) (Cork)	1	92-Up	83300B	13974X
300K	Gasket, Bottom Pan (21 Bolts) (RE4F04A, RE4F04B, 4F20E) (Fiber).....	1	92-Up	83300BF	13974F
300K	Gasket, Bottom Pan (21 Bolts) (JF403E) (Cork).....	1	90-93	83300C	13972X
300K	Gasket, Bottom Pan (21 Bolts) (JF403E) (Fiber).....	1	90-93	83300CF	13972F
300K	Gasket, Bottom Pan (22 Bolts) (LJ4A-EL) (Fiber).....	1	95-Up	83300DF	13972AF
311A	O-Ring, Pump to Case.....	1	90-Up	83311B	13989A
TECHNICAL MANUALS					
400K	Tech Manual (RE4F04A).....	1	92-Up	83400B	82Y03
400K	Tech Manual (4F20E)	1	92-Up	83400D	82Y04

RE4F04A

RE4F04A, RE4F04B JF403E, LJ4A-EL

ILL.	DESCRIPTION	QTY.	YEAR	PART NO.	REFERENCE NO.
ELECTRICAL COMPONENTS					
420	Solenoid Assembly (JF403E).....	1	90-Up	83420A	31A-130
420	Solenoid Assembly (LJ4A-EL).....	1	95-Up	83420C	31A-130A
420	Solenoid Assembly (RE4F04A, 4F20E) (Long Wire Design)	1	92-Up	83420B	31A-129
420	Solenoid Assembly (RE4F04B) (Short Wire Design)	1	00-Up	83420BA	31A-129A
HARD PARTS					
Prefix Key: D = OEM, A = Aftermarket New, R = Remanufactured					
PUMPS					
500A	Pump Complete (9 T on Inner Gear) (Cast Iron Stator) (JF403E)	1	90-Up	83500AE	82920
500A	Pump Complete (11 T on Inner Gear) (Aluminum Stator) (RE4F04A).....	1	92-Up	83500BA	82920D
DRUMS & CLUTCH HUBS					
554I	Forward (JF403E, LJ4A-EL)	1	90-Up	83554AE	82929
554I	Forward (RE4F04A, RE4F04B, 4F20E)	1	92-Up	83554BA	82929D
555G	High w/ Input Shaft (28 T Steels) (JF403E, LJ4A-EL)	1	90-Up	83555AE	82925
555G	High w/ Input Shaft (8 T Steels) (RE4F04A, RE4F04B, 4F20E).....	1	92-Up	83555BA	82925D
556A	Reverse (30 Drive Lugs) (JF403E, LJ4A-EL)	1	90-Up	83556AE	82923
556A	Reverse (16 Drive Lugs) (RE4F04A, RE4F04B, 4F20E) (Exc 3.5L)	1	92-Up	83556BA	82923D
575B	Hub, High Clutch (21 T 3-1/2" OD) (4F20E).....	1	92-Up	83575D	82927E
575B	Hub, High Clutch (24 T 3-1/2" OD) (RE4F04A, RE4F04B) (Exc 3.5L).....	1	92-Up	83575BA	82927D
PLANETS					
582H	Front (33 T) (RE4F04A, RE4F04B, 4F20E).....	1	90-Up	83582BA	82950D
584H	Rear w/ Front Planet Ring Gear (37 T Sun Gear) (JF403E, LJ4A-EL)	1	90-Up	83584AE	82955B
584H	Rear w/ Front Planet Ring Gear (42 T Sun Gear) (RE4F04A, RE4F04B, 4F20E).....	1	92-Up	83584BA	82955
583H	Planet Kit (w/ 37 T Sun Gear) (JF403E, LJ4A-EL)	1	92-Up	83583AE	K82950
583H	Planet Kit (w/ 42 T Sun Gear) (RE4F04A, RE4F04B, 4F20E)	1	92-Up	83583AA	K82950D
594H	Ring Gear, Rear (.870" Tall Sprag Race) (JF403E, LJ4A-EL)	1	90-Up	83594AE	82972
594H	Ring Gear, Rear (.990" Tall Sprag Race) (RE4F04A, RE4F04B, 4F20E).....	1	92-Up	83594BA	82972D
SPRAGS					
642B	Sprag Assembly, Low (18 Roller)	1	90-Up	83642B	82960
658H	Sprag, Forward (.410" Wide Lugs) (JF403E, LJ4A-EL)	1	90-Up	83658AE	82940
658H	Sprag, Forward (.530" Wide Lugs) (RE4F04A, RE4F04B, 4F20E)	1	92-Up	83658BA	82940B
VALVE BODIES					
740J	Valve Body (Premium) (LJ4A-EL)	1	95-Up	83740-3	P82990G
740J	Valve Body (Premium) (RE4F04A) (Long Wire).....	1	92-Up	83740-2	P82990D
740J	Valve Body (Premium) (RE4F04B) (Short Wire)	1	00-Up	83740-4	P82990F
741K	Valve, Pressure Regulator (Oversized) (requires T-63940-TL Reamer)	1	92-Up	83741PK	K82882
741K	Valve Kit, 1-2 Accumulator (requires T-63940-BST Sizing Tool)	1	92-Up	83741EK	K82886
741K	Valve, Accumulator Shift	1	92-Up	83741EAK	K82887
MISCELLANEOUS COMPONENTS					
854	Drum Saver Kit, Reverse	1	90-Up	83854K	K82101A
857H	Cushion Spring, Low/ Rev Clutch (No Lug, 5.965" ID)	1	90-Up	83857B	82957
965G	Retainer, High Clutch (Bonded) (RE4F04B)	1	03-Up	83965BA	82532

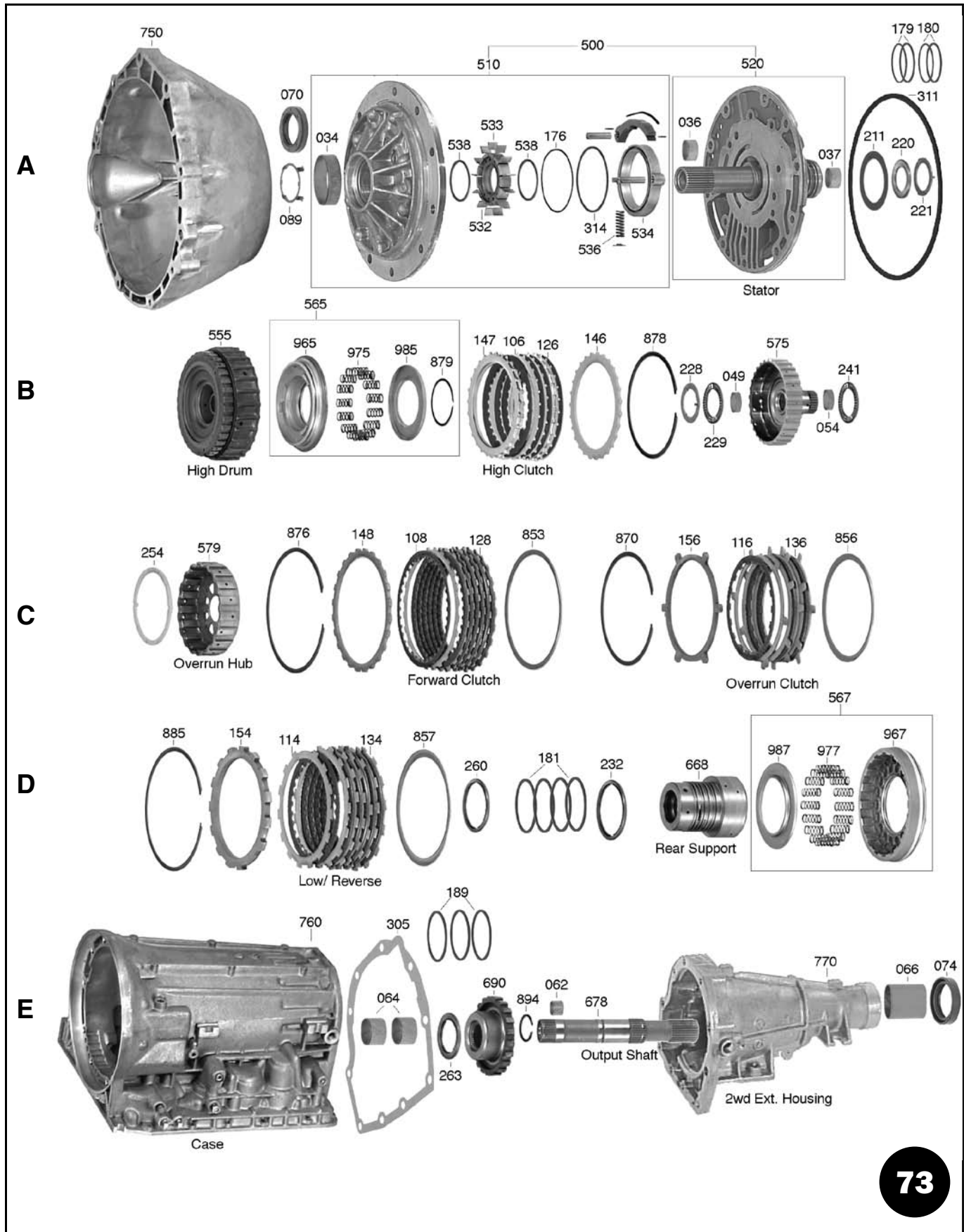

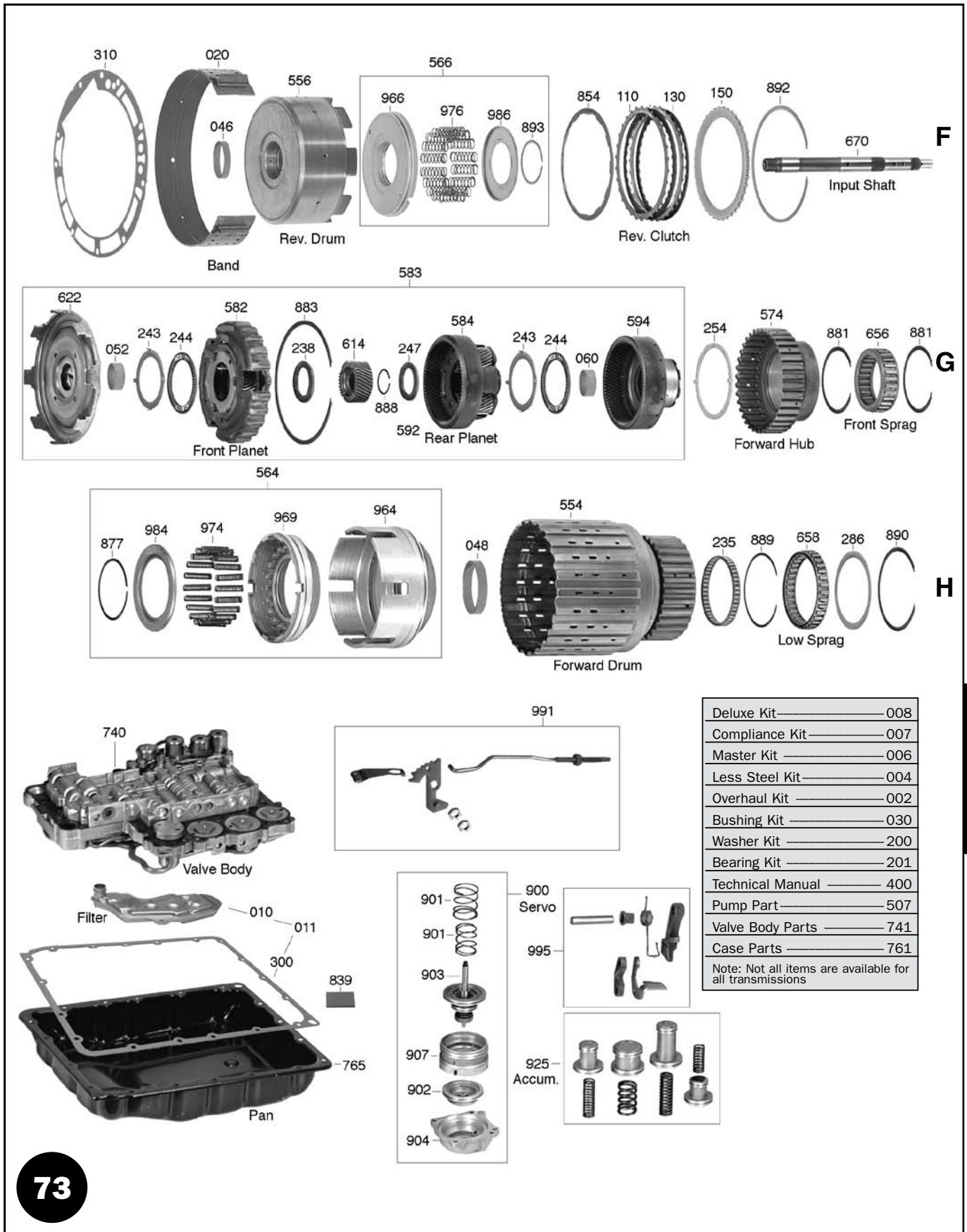

Deluxe Kit	008
Compliance Kit	007
Master Kit	006
Less Steel Kit	004
Overhaul Kit	002
Bushing Kit	030
Washer Kit	200
Bearing Kit	201
Technical Manual	400
Pump Part	507
Valve Body Parts	741
Case Parts	761

Note: Not all items are available for all transmissions

NISSAN RL4R01A, RE4/5R01A FWD - 4 SPEED

MAZDA R4A-EL 2/4 WD - RWD



73010A



73010B



A73010AA



73300



A73010A



A73010B



A73010C



A73010D

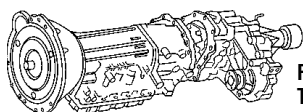

Rear Wheel Drive
Transmission w/Transfer Case
Illustrated

NOTE: Q45 Could also be equipped with a 5 Speed RE5R05A.

ILL.	DESCRIPTION	QTY.	YEAR	PART NO.	REFERENCE NO.
MASTER OVERHAUL KITS (WITH STEELS)					
006H	Nissan (RE5R01A) (5 Speed).....	1	91-Up	73006RF	K7800F
006H	Nissan (2wd Exc 300ZX Non Turbo, Infiniti J30), Mazda (2wd, 4wd).....	1	87-92	73006AF	N/A
006H	Nissan (2wd Exc 300ZX Non Turbo, Infiniti J30), Mazda (2wd, 4wd).....	1	93-E96	73006ABF	K7800A
006H	Nissan (2wd Exc 300ZX Non Turbo, Infiniti J30) (Does Not Fit 3.5L).....	1	L96-Up	73006DF	K7800B
006H	Nissan (4wd, Also 300ZX Non Turbo, Infiniti J30).....	1	87-92	73006BF	N/A
006H	Nissan (4wd, Also 300ZX Non Turbo, Infiniti J30).....	1	93-E96	73006BBF	K7800
006H	Nissan (4wd, Also 300ZX Non Turbo, Infiniti J30) (Does Not Fit 3.5L).....	1	L96-Up	73006DF	K7800B
006H	Nissan (3.5L).....	1	L96-Up	73006HF	N/A
LESS STEEL KITS					
004H	Nissan (RE5R01A) (5 Speed).....	1	91-Up	73004RF	K7800F-LS
004H	Nissan (2wd Exc 300ZX Non Turbo, Infiniti J30), Mazda (2wd, 4wd).....	1	87-92	73004AF	N/A
004H	Nissan (2wd Exc 300ZX Non Turbo, Infiniti J30), Mazda (2wd, 4wd).....	1	93-E96	73004ABF	K7800A-LS
004H	Nissan (2wd Exc 300ZX Non Turbo, Infiniti J30) (Does Not Fit 3.5L).....	1	L96-Up	73004DF	K7800B-LS
004H	Nissan (4wd, Also 300ZX Non Turbo, Infiniti J30).....	1	87-92	73004BF	N/A
004H	Nissan (4wd, Also 300ZX Non Turbo, Infiniti J30).....	1	93-E96	73004BBF	K7800-LS
004H	Nissan (4wd, Also 300ZX Non Turbo, Infiniti J30) (Does Not Fit 3.5L).....	1	L96-Up	73004DF	K7800B-LS
004H	Nissan (3.5L).....	1	L96-Up	73004HF	N/A
OVERHAUL KITS (W/ RINGS & SEALS)					
002H	RL4R01A, RE4R01A, R4A-EL (4 Speed).....	1	87-Up	73002AF	K78900
002H	RE5R01A (5 Speed).....	1	91-Up	73002RF	K78900F
FILTER KITS					
011H	Nissan 4 Cyl 2wd (.125" Tall Square Pick-Up Tube).....	1	90-Up	73011AA	FK78800B
011H	Nissan 6 Cyl 2wd (.160" Tall Round Pick-Up Tube) (Metal & Plastic) (1)	1	87-Up	73011A	FK78800AS
011H	Nissan 6 Cyl 2wd (.300" Tall Square Pick-Up Tube) (All Metal) (1)	1	87-Up	A73011A	FK78800A
011H	Nissan 6 Cyl 2wd (.750" Tall Round Pick-Up Tube) (Metal & Plastic) (2)	1	87-Up	73011B	FK78800S
011H	Nissan 6 Cyl 2wd (.950" Tall Square Pick-Up Tube) (All Metal) (2)	1	87-Up	A73011B	FK78800
011H	Nissan 6 Cyl 4wd (.750" Tall Round Pick-Up Tube) (Metal & Plastic).....	1	87-Up	73011B	FK78800S
011H	Nissan 6 Cyl 4wd (.950" Tall Square Pick-Up Tube) (All Metal).....	1	87-Up	A73011B	FK78800
011H	Mazda Exc. 929 & RX7 (.950" Tall Square Pick-Up Tube).....	1	87-Up	73011B	FK78800S
011H	Mazda 929 (.875" Tall Square Pick-Up Tube).....	1	87-Up	73011D	N/A
011H	Mazda RX7 (1.875" Tall Square Pick-Up Tube).....	1	87-Up	73011C	FK78800E
	(1) does not fit 2wd Supercharged Frontier/Xterra, 12/98-Up 2wd Pathfinder				
	(2) Fits 2wd Supercharged Frontier/Xterra, 12/98-Up 2wd Pathfinder				

MAZDA R4A-EL 2/4 WD - RWD

NISSAN RL4R01A, RE4/5R01A FWD - 4 SPEED

ILL.	DESCRIPTION	QTY.	YEAR	PART NO.	REFERENCE NO.
FILTERS					
010H	Nissan 4 Cyl 2wd (.125" Tall Square Pick-Up Tube)	1	90-Up	A73010AA	78800B
010H	Nissan 6 Cyl 2wd (.160" Tall Round Pick-Up Tube) (Metal & Plastic) (1)	1	87-Up	73010A	78800AS
010H	Nissan 6 Cyl 2wd (.300" Tall Square Pick-Up Tube) (All Metal) (1)	1	87-Up	A73010A	78800A
010H	Nissan 6 Cyl 2wd (.750" Tall Round Pick-Up Tube) (Metal & Plastic) (2)	1	87-Up	73010B	78800S
010H	Nissan 6 Cyl 2wd (.950" Tall Square Pick-Up Tube) (All Metal) (2)	1	87-Up	A73010B	78800
010H	Nissan 6 Cyl 4wd (.750" Tall Round Pick-Up Tube) (Metal & Plastic)	1	87-Up	73010B	78800S
010H	Nissan 6 Cyl 4wd (.950" Tall Square Pick-Up Tube) (All Metal)	1	87-Up	A73010B	78800
010H	Mazda Exc. 929 & RX7 (.950" Tall Square Pick-Up Tube)	1	87-Up	73010B	78800
010H	Mazda 929 (.875" Tall Square Pick-Up Tube)	1	87-Up	A73010D	N/A
010H	Mazda RX7 (2" Tall Square Pick-Up Tube)	1	87-Up	A73010C	78800E
<p>(1) does not fit 2wd Supercharged Frontier/Xterra, 12/98-Up 2wd Pathfinder (2) Fits 2wd Supercharged Frontier/Xterra, 12/98-Up 2wd Pathfinder</p>					
BANDS					
Prefix Key: B = Borg Warner, A = OEM (Exc. BW), N = All Other New, R = Relined					
020F	Overdrive (1.500" Wide) (Only One End Has Tab)	1	87-Up	73020	78700
020F	Overdrive (1.500" Wide) (Both Ends Same)	1	99-Up	93020	68700
020F	Overdrive (2.362" Wide) (Both Ends Same) (3.5L)	1	02-Up	73020A	78700C
BUSHINGS					
030H	Bushing Kit	1	87-Up	73030	K78901
034A	Pump Body	1	87-Up	93034	68001
036A	Stator (Front) (.845" ID)	1	87-Up	73036	78002A
036A	Stator (Front) (.945" ID)	1	87-Up	73036A	78002
037A	Stator (Rear)	1	87-Up	93037	68004
046F	Reverse Drum	1	87-Up	93046	68005
048F	Forward Drum	1	87-Up	73048	78009
052F	Front Sun Gear (Shell)	1	87-Up	93052	68007
054B	High Clutch Hub	2	87-Up	73054	68006
060G	Rear Ring Gear	1	87-Up	73060	78008A
062E	Output Shaft (Front)	1	87-Up	73062	80010
064E	Case	2	87-Up	73064	78011
064E	Case (Babbitt 1 Piece, Replaces 2 Case Bushings)	1	87-Up	73064BA	N/A
066E	Extension Housing	1	87-Up	73066	45014B
METAL CLAD SEALS					
070A	Front	1	87-Up	93070	68200
072	Manual Lever	1	87-Up	73072	78204
074E	Extension Housing (Nissan, Infiniti)	1	87-Up	53074B	45201B
074E	Extension Housing (Mazda Exc. 93-Up RX7)	1	87-Up	53074D	45201C
074E	Extension Housing (Mazda 93-Up RX7)	1	93-Up	73074B	78205R
074E	Adapter Housing (Mazda 4wd)	1	87-Up	73074C	45201D
074E	Adapter Housing (Nissan 4wd)	1	87-Up	73074D	78203
089A	Seal Retainer, Front Seal Lock	1	87-Up	73089	78991
FRICITION PLATES					
106B	High .063" (30 T)	4-5	87-Up	93106B	68103B
108C	Forward .063" (36 T)	5-7	87-Up	73108A	78104
108C	Forward .079" (36 T)	5-7	87-Up	73108	78104A
110F	Reverse .079" (30 T)	2	93-Up	73110AA	78100A
110F	Reverse .079" (34 T)	2	87-Up	93110A	68100A
114D	Low/ Reverse .079" (30 T)	7	87-Up	73114	78108
116C	Overrun .079" (18 T)	3	87-92	73116	78106

RE4R01A

NISSAN RL4R01A, RE4/5R01A FWD - 4 SPEED

MAZDA R4A-EL 2/4 WD - RWD

ILL.	DESCRIPTION	QTY.	YEAR	PART NO.	REFERENCE NO.
STEEL PLATES					
126B	High .067" (27 T).....	4-7	87-Up	73126	68102D
126B	High .079" (27 T).....	3-5	87-Up	93126BA	68102C
126B	High .118" (27 T).....	AR	87-Up	93126B	68102A
128C	Forward .071" (24 T).....	5-7	87-Up	73128	78105
128C	Forward .079" (24 T).....	5-7	87-Up	73128A	78105A
130F	Reverse .079" (5.050" ID) (30 T).....	2	93-Up	73130B	78101A
130F	Reverse .079" (5.300" ID) (30 T).....	2	87-Up	93130A	68101A
130F	Reverse .110" (V-Tooth) (3.5L).....	2	02-Up	73130C	78101C
134D	Low/ Reverse .051" (14 T).....	AR	87-Up	73134A	N/A
134D	Low/ Reverse .079" (14 T).....	4-7	87-Up	73134	78109
136C	Overrun .079" (4.700" ID) (6 T).....	3-5	87-Up	73136	78107
PRESSURE PLATES					
Prefix Key: D = OEM, A = Aftermarket New, R = Remanufactured					
146B	High Clutch (3.6mm) (27 T).....	1	87-Up	73146A	N/A
146B	High Clutch (4.0mm) (27 T).....	1	87-Up	73146AB	N/A
146B	High Clutch (4.2mm) (27 T).....	1	87-Up	73146AC	N/A
146B	High Clutch (4.4mm) (27 T).....	1	87-Up	73146AD	N/A
150F	Reverse Clutch (4.8mm) (30 T).....	1	87-Up	73150AA	N/A
150F	Reverse Clutch (5.0mm) (30 T).....	1	87-Up	73150AB	N/A
VALVE BODY RECALIBRATION KITS					
165H	Shift Kit® (Transgo®).....	1	88-Up	T73165A	K78908
165H	Shift Correction Package (RE4R01A) (Superior).....	1	88-Up	S73165A	78C01
SEALING RINGS					
175H	Ring Kit.....	1	87-Up	73175	K78903
THRUST WASHERS					
211A	Stator to Reverse Drum .028" (Plastic).....	1	87-Up	93211	78400
211A	Stator to Reverse Drum .035" (Plastic).....	1	87-Up	93211A	78400A
211A	Stator to Reverse Drum .043" (Plastic).....	1	87-Up	93211B	78400B
211A	Stator to Reverse Drum .051" (Plastic).....	1	87-Up	93211C	78400C
211A	Stator to Reverse Drum .067" (Plastic).....	1	87-Up	93211E	78400E
211A	Stator to Reverse Drum .075" (Plastic).....	1	87-Up	93211F	78400F
254C	Rear Planet Ring Gear to Clutch Hub 3 13/16" OD (Plastic).....	2	87-Up	73254	78401
BEARINGS & RACES					
201H	Bearing Kit, w/ Washers.....	1	87-Up	73201A	K78500
201H	Bearing Kit, Planet Assembly.....	1	87-Up	73201	K78500S
220A	Bearing w/ Race, Stator to High Drum.....	1	87-Up	73220	78501
221A	Race, Stator to High Drum .055" (Metal w/ 3 Outer Tabs).....	1	87-Up	93221AB	78500C
221A	Race, Stator to High Drum .063" (Metal w/ 3 Outer Tabs).....	1	87-Up	93221AC	N/A
221A	Race, Stator to High Drum .079" (Metal w/ 3 Outer Tabs).....	1	87-Up	93221AE	78500F
228B	Race, High Drum to Hub (Metal w/ 3 Inner Tabs).....	1	87-Up	73228	78502
232D	Bearing w/ Race, High Drum to Hub (Also High Hub to Sun Shell).....	1	87-Up	53232	N/A
232D	Bearing, Forward Drum to Hub (Update Replaces Bearing w/ Race).....	2	87-Up	73232B	78510
238G	Bearing w/ Race, Front Planet to Rear Sun Gear.....	1	87-Up	73238	N/A
243G	Race, Shell to Front Planet & Rear Planet to Ring Gear.....	2	87-Up	73243	N/A
244G	Bearing w/ Race, Shell to Front Planet & Rear Planet to Rear Ring Gear.....	2	87-Up	73244	78505
244G	Bearing w/ Race Kit, Includes (1) 73243 & (1) 73244.....	1	87-Up	73244K	N/A
247G	Bearing w/ Race, Rear Sun Gear to Rear Planet.....	1	87-Up	73247	78507
260D	Bearing w/ Race, Overrun Hub to Rear Support.....	1	87-Up	73260	N/A
260D	Bearing w/ 2 Races, Overrun Hub to Rear Support.....	1	87-Up	73260A	78509A
263H	Bearing w/ Race, Case to Park Gear.....	1	87-Up	73263	78511

MAZDA R4A-EL 2/4 WD - RWD

NISSAN RL4R01A, RE4/5R01A FWD - 4 SPEED

ILL.	DESCRIPTION	QTY.	YEAR	PART NO.	REFERENCE NO.
GASKETS & O-RINGS					
300H	Gasket, Bottom Pan (Cork).....	1	87-Up	73300	13885X
300H	Gasket, Bottom Pan (Fiber).....	1	87-Up	73300F	13885F
305E	Gasket, Extension Housing.....	1	87-Up	73305A	13887
310F	Gasket, Pump.....	1	87-Up	73310A	13883M
311A	O-Ring, Pump.....	1	87-Up	73311	13884
320	Gasket Kit, Valve Body (RE4R01A, R4A-EL).....	1	87-Up	73320K	K13849
379	O-Ring, Filter.....	1	87-Up	73379	13808
TECHNICAL MANUALS					
400H	Tech Manual, RE4R01A.....	1	87-Up	73400	78Y01
400H	Tech Manual, RL4R01A.....	1	87-Up	73400A	78Y02
ELECTRICAL COMPONENTS					
420	Solenoid Assembly (4 Solenoids, 2 Insulated Connectors, 1 Ground Wire).....	1	L88-Up	73420A	31A-125
425	Solenoid, Lock-Up (Non PWM) (Exc. R4A-EL).....	1	87-Up	73425	31A-125L
425	Solenoid, Lock-Up (PWM) (R4A-EL).....	1	92-Up	73425B	31A-125P
425	Solenoid, Lock-Up (Lock-up & Overdrive Cancel).....	2	90-Up	73425A	5A-185
445	Repair Kit, External Wire Harness (7 Plug-ins, Fits 7-Prong Connector).....	1	87-Up	73445EAK	N/A
445	Repair Kit, External Wire Harness (7 Prong).....	1	87-Up	73445EK	N/A
HARD PARTS					
Prefix Key: D = OEM, A = Aftermarket New, R = Remanufactured					
PUMPS					
500A	Pump Complete (Front Stator Bushing .845" ID) (RL4R01A w/ Lugs).....	1	87-Up	73500A	78920
500A	Pump Complete (Front Stator Bushing .845" ID) (RL4R01A w/ Flats).....	1	87-Up	73500AE	78920G
500A	Pump Complete (Front Stator Bushing .945" ID, Switch on Back) (w/ Sensor).....	1	87-Up	73500AB	78920D
500A	Pump Complete (Front Stator Bushing .945" ID, No Switch) (w/o Sensor).....	1	87-Up	73500AA	78920A
500A	Pump Complete (Milled Flats on Rotor) (w/ Sensor).....	1	87-Up	73500AC	78920E
500A	Pump Complete (Milled Flats on Rotor) (w/o Sensor).....	1	87-Up	73500AD	78920F
DRUMS & CLUTCH HUBS					
554H	Forward (Low/ Reverse Clutch Hub Spline Length is 1.645" Tall).....	1	87-Up	73554A	78925
554H	Forward (Low/ Reverse Clutch Hub Spline Length is 1.765" Tall).....	1	87-Up	73554	78925A
555B	High (w/ 34 T Reverse Hub) (can use 93555).....	1	87-92	73555	78922
555B	High (w/ 30 T Reverse Hub) (1.575" Band).....	1	93-Up	73555A	78922B
555B	High (w/ 30 T Reverse Hub) (2.360" Band) (3.5L).....	1	02-Up	73555B	78922C
556E	Reverse (1.575" Band).....	1	87-Up	73556	78921
556E	Reverse (2.360" Band) (3.5L).....	1	02-Up	73556B	78921C
854F	Reverse Drum Saver Kit (Waved Cushion Plate Fix by Alto).....	1	87-92	73854K	K78101B
854F	Reverse Drum Saver Kit (Waved Cushion Plate Fix by Alto).....	1	93-Up	73854AK	K78101A
574G	Clutch Hub, Forward (1.280" Tall At Clutch Splines).....	1	87-Up	73574A	N/A
574G	Clutch Hub, Forward (1.330" Tall At Clutch Splines).....	1	87-Up	73574	78927
574G	Clutch Hub, Forward (1.410" Tall At Clutch Splines).....	1	87-Up	73574B	N/A
575B	Clutch Hub, High (All 87-89).....	1	87-89	73575	78923
575B	Clutch Hub, High (90-Up 2wd).....	1	90-Up	73575A	N/A
575B	Clutch Hub, High (90-Up 4wd).....	1	90-Up	73575	78923
579C	Clutch Hub, Overrun.....	1	87-Up	73579	78937
PLANETS					
582G	Front (No Groove).....	1	87-Up	73582A	78983
582G	Front (2 Grooves).....	1	87-Up	73582	N/A
583G	Planet Kit (Includes # 622 to # 594) (37 T Rear Sun Gear).....	1	87-Up	73583	K78980A
583G	Planet Kit (Includes # 622 to # 594) (42 T Rear Sun Gear).....	1	87-Up	73583B	K78980C

RE4R01A

NISSAN RE4R03A/JR403E

4 SPEED - RWD

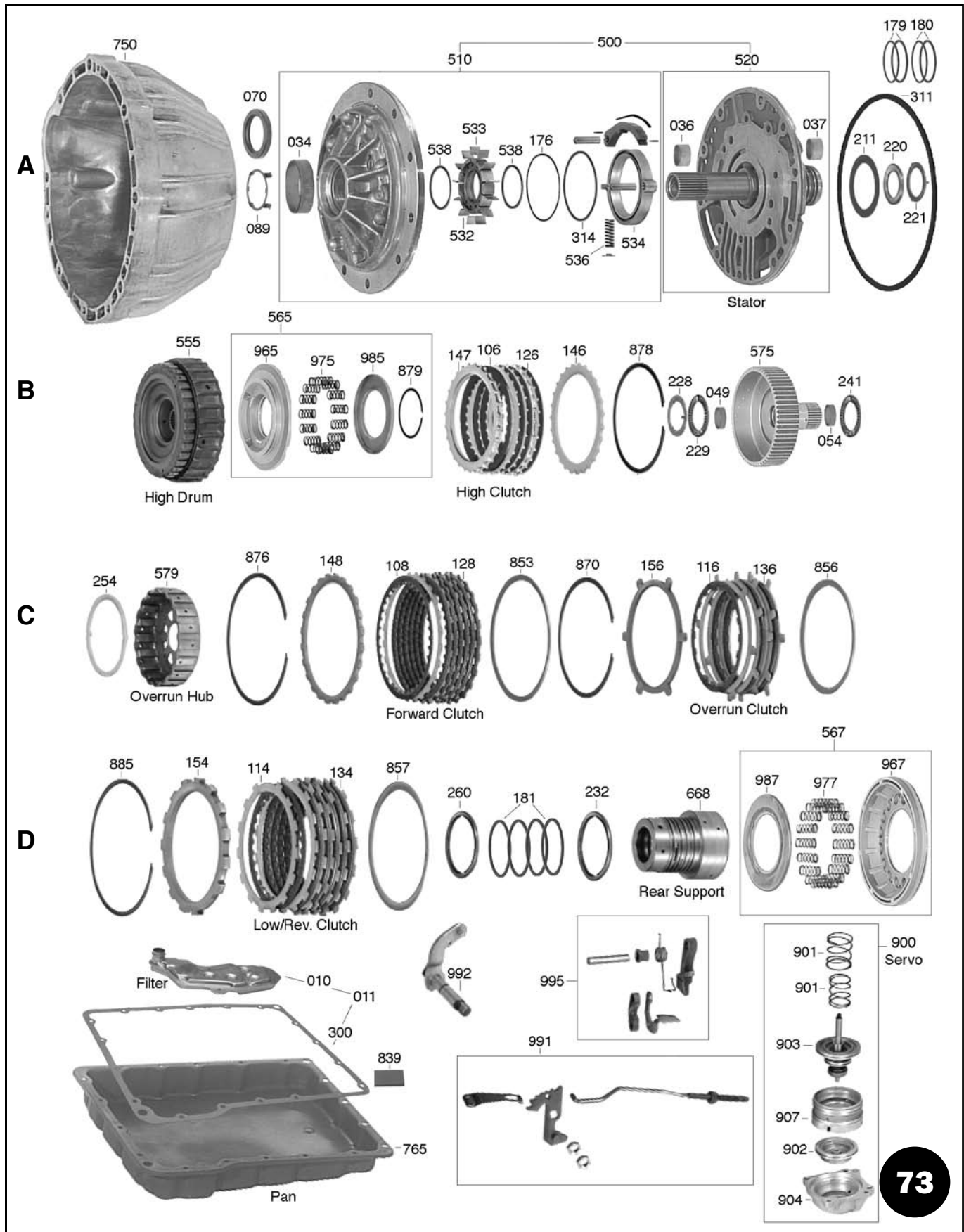

NISSAN RE4R03A/JR403E 4 SPEED - RWD

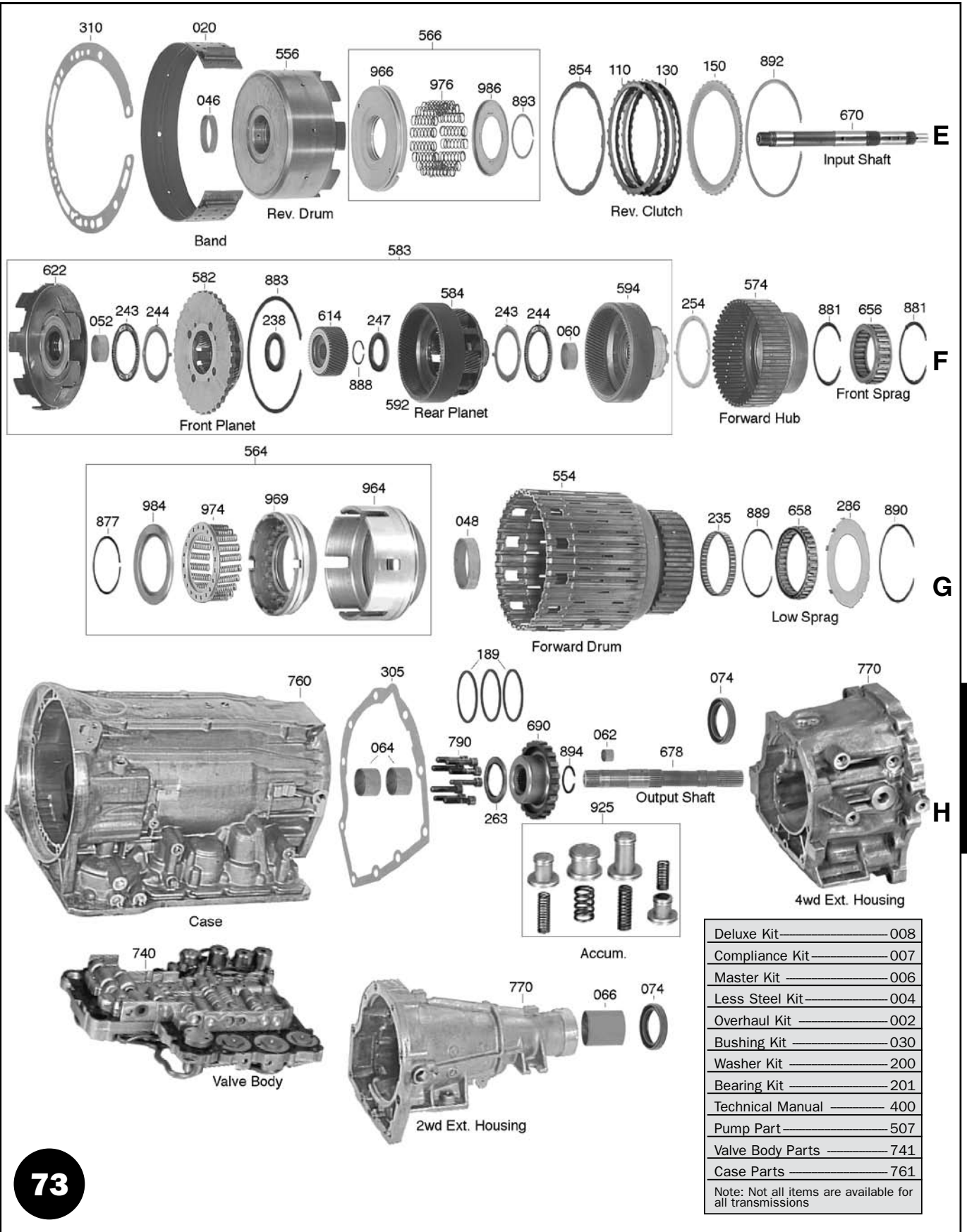

NISSAN RE4R03A/JR403E 4 SPEED - RWD



73010B



A73010B



73010Q

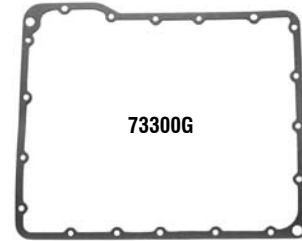

73300G

ILL.	DESCRIPTION	QTY.	YEAR	PART NO.	REFERENCE NO.
MASTER OVERHAUL KITS (WITH STEELS)					
006H	RE4R03A (300ZX w/ Twin Turbo)	1	90-Up	73006QCF	N/A
006H	RE4R03A (Infiniti Q45 V8)	1	90-Up	73006QDF	K7800M
006H	RG4R01A, JR403E	1	88-Up	73006GF	K8000
LESS STEEL KITS					
004H	RE4R03A (300ZX w/ Twin Turbo)	1	90-Up	73004QCF	N/A
004H	RE4R03A (Infiniti Q45 V8)	1	90-Up	73004QDF	K7800M-LS
004H	RG4R01A, JR403E	1	88-Up	73004GF	K8000-LS
OVERHAUL KITS (W/ RINGS & SEALS)					
002H	RE4R03A	1	90-Up	73002QF	K78900M
002H	RG4R01A, JR403E	1	88-Up	73002GF	K80900
FILTER KITS					
011D	RE4R03A (No Pick-up Tube)	1	89-Up	73011Q	FK78800C
011D	RG4R01A, JR403E (w/ Pick-up Tube)	1	88-Up	73011BG	FK78800
FILTERS					
010D	RE4R03A (No Pick-Up Tube)	1	89-Up	73010Q	78800C
010D	RG4R01A, JR403E (3/4" Tall Round Pick-up Tube)	1	88-Up	73010B	78800
010D	RG4R01A, JR403E (7/8" Tall Rectangular Pick-up Tube) (can use 73010B)	1	88-Up	A73010B	78800
BANDS					
Prefix Key: B = Borg Warner, A = OEM (Exc. BW), N = All Other New, R = Relined					
020E	Overdrive (2 1/4" Wide)	1	88-Up	73020G	78700A
BUSHINGS					
030H	Bushing Kit	1	88-Up	73030G	K80901
034A	Pump Body	1	88-Up	93034	68001
036A	Stator (Front) (1.048" ID, 1.146" OD)	1	88-Up	73036G	80002
046E	Reverse Drum	1	88-Up	73046G	80005
048G	Forward Drum	1	88-Up	73048	78009
049B	High Hub	2	88-Up	73054G	80006
062H	Output Shaft (Front)	1	88-Up	73062	80010
064H	Case	2	88-Up	73064G	80011
066H	Extension Housing	1	88-Up	73066G	80012
METAL CLAD SEALS					
070A	Front	1	88-Up	93070	68200
072	Manual Lever	1	88-Up	73072	78204
074H	4wd Adapter Housing (RG4R01A, JR403E) Nissan	1	88-Up	73074D	78203
074H	Extension Housing (RG4R01A, JR403E) Nissan	1	88-Up	73074G	80201A
074H	Extension Housing (RG4R01A, JR403E) Isuzu	1	88-Up	73074H	80201
074H	Extension Housing (RE4R03A)	1	90-Up	73074Q	78205
089	Front Seal Retainer	1	90-Up	73089	78991

NISSAN RE4R03A/JR403E 4 SPEED - RWD

ILL.	DESCRIPTION	QTY.	YEAR	PART NO.	REFERENCE NO.
FRICITION PLATES					
106B	High .062" (64 T).....	6-7	88-Up	73106G	78103
108C	Forward .079" (50 T).....	7-9	88-Up	73108G	78104B
110E	Reverse .075" (64 T).....	3	88-Up	73110G	78100
114D	Low/ Reverse .064" (33 T).....	7-8	88-Up	73114G	78108A
116C	Overrun .062" (20 T).....	5	88-Up	73116Q	78106B
116C	Overrun .079" (20 T).....	5	88-Up	73116G	78106A
STEEL PLATES					
126B	High .079" (40 T).....	7	88-Up	73126Q	78101
126B	High .118" (40 T).....	7-10	88-Up	73126G	78101B
128C	Forward .079" (36 T).....	7-14	88-Up	73128G	78105B
130E	Reverse .079" (40 T).....	3	88-Up	73126Q	78101
134D	Low/ Reverse .079" (11 T).....	6-9	88-Up	73134G	78109A
136C	Overrun .079" 5.360" ID (6 T).....	5-7	88-Up	73136G	78107A
PRESSURE PLATES					
Prefix Key: D = OEM, A = Aftermarket New, R = Remanufactured					
146B	High (4.4mm) (40 T).....	1	88-Up	73146G	N/A
150E	Reverse (4.4mm) (40 T).....	1	88-Up	73146G	N/A
VALVE BODY RECALIBRATION KITS					
165H	Shift Kit® (RE4R03A, RG4R01A, JR403E) (Transgo®).....	1	88-Up	T73165A	K78908
SEALING RINGS					
175H	Ring Kit (RE4R03A).....	1	88-Up	73175	K78903
175H	Ring Kit (RG4R01A, JR403E).....	1	88-Up	73175G	K80903
THRUST WASHERS					
211A	Stator to Reverse Drum .028" (Plastic).....	1	88-Up	93211	78400
211A	Stator to Reverse Drum .035" (Plastic).....	1	88-Up	93211A	78400A
211A	Stator to Reverse Drum .043" (Plastic).....	1	88-Up	93211B	78400B
211A	Stator to Reverse Drum .051" (Plastic).....	1	88-Up	93211C	78400C
211A	Stator to Reverse Drum .067" (Plastic).....	1	88-Up	93211E	78400D
211A	Stator to Reverse Drum .075" (Plastic).....	1	88-Up	93211F	78400F
254C	Rear Planet Ring Gear to Clutch Hub.....	1	88-Up	73254G	80401
BEARINGS & RACES					
201H	Bearing Kit (RE4R03A).....	1	88-Up	73201Q	K78500M
201H	Bearing Kit (RG4R01A, JR403E).....	1	88-Up	73201GB	K80500
201H	Bearing Kit (RG4R01A, JR403E) (Partial).....	1	88-Up	73201GA	K80500S
201H	Bearing Kit, Planet Assembly (RG4R01A, JR403E).....	1	88-Up	73201G	N/A
228B	Race, High Drum to Hub (Metal w/ 3 Inner Tabs).....	1	88-Up	73228	78502
232D	Bearing w/ Race, High Drum to Hub.....	1	88-Up	53232	N/A
232D	Bearing, Forward Drum to Hub (Update Replaces Bearing w/ Race).....	2	87-Up	73232B	78510
238F	Bearing w/ Race, Front Planet to Rear Sun Gear (RG4R01A, JR403E).....	1	88-Up	73238G	N/A
238F	Bearing w/ Race, Front Planet to Rear Sun Gear (RE4R03A).....	1	90-Up	73247	78507
241B	Bearing w/ Race, High Hub to Sun Shell.....	1	88-Up	73241G	80503A
243F	Race, Rear Planet to Rear Ring Gear (4 Outer Tabs) (RG4R01A, JR403E).....	1	88-Up	73243GA	N/A
244F	Bearing w/ Race, Shell to Front Planet.....	1	88-Up	73241G	80503A
244F	Bearing w/ Race, Rear Planet to Rear Ring Gear (RG4R01A, JR403E).....	1	88-Up	73241G	80503A
247F	Bearing w/ Race, Rear Sun Gear to Rear Planet (RE4R03A).....	1	90-Up	73247	78507
GASKETS & O-RINGS					
300D	Gasket, Bottom Pan (Cork).....	1	88-Up	73300G	13885A
300D	Gasket, Bottom Pan (Fiber).....	1	88-Up	73300GF	13885AF

RE4R03A

NISSAN RE4R03A/JR403E

4 SPEED - RWD

ILL.	DESCRIPTION	QTY.	YEAR	PART NO.	REFERENCE NO.
GASKETS & O-RINGS (Cont.)					
305	Gasket, Extension Housing (RE4R03A)	1	88-96	73305A	13887
310E	Gasket, Pump (RE4R03A)	1	90-Up	73310A	13883M
310E	Gasket, Pump (RG4R01A, JR403E)	1	88-Up	73310G	N/A
311A	O-Ring, Pump	1	88-Up	73311	13884
344	Seal, Center Support (RG4R01A, JR403E)	4	88-Up	73344	13918
TECHNICAL MANUALS					
400H	Tech Manual, RG4R01A, JR403E Electromatic	1	88-Up	73400G	80Y01
ELECTRICAL COMPONENTS					
420	Solenoid Assy (4 Solenoids, 2 Insulated Connectors, 1 Ground Wire)	1	88-Up	73420A	31A-125
425	Solenoid, Lock-Up (Non PWM)	1	88-Up	73425	31A-125L
HARD PARTS					
Prefix Key: D = OEM, A = Aftermarket New, R = Remanufactured					
PUMPS					
500A	Pump Complete (RE4R03A) (w/ Sensor)	1	90-Up	73500Q	78920M
500A	Pump Complete (RE4R03A) (w/o Sensor)	1	90-Up	73500QA	78920P
500A	Pump Complete (RG4R01A, JR403E)	1	88-Up	73500G	80920
DRUMS & CLUTCH HUBS					
554G	Forward w/o Sprag (8 3/4" Tall) (RE4R03A)	1	90-Up	73554Q	78925M
554G	Forward w/o Sprag (9 1/8" Tall) (RG4R01A, JR403E)	1	88-Up	73554G	80925B
555B	High (6 Clutch) (RG4R01A, JR403E)	1	88-Up	73555G	80922
556E	Reverse	1	88-Up	73556G	80921
PLANETS					
583F	Planet Kit (Incl # 622 to # 594) (44 T Rear Sun Gear) (RG4R01A, JR403E)	1	88-Up	73583G	K80980
583F	Planet Kit (Incl # 622 to # 594) (51 T Rear Sun Gear) (RE4R03A)	1	88-Up	73583Q	K78980M
583F	Planet Kit (Incl # 622 to # 594) (58 T Rear Sun Gear) (RE4R03A)	1	88-Up	73583QD	K78980N
SUN GEARS, SHELLS & SUPPORTS					
622F	Shell (w/ 40 T Sun Gear)	1	88-Up	73622G	N/A
630	Front Support (Reverse Clutch Drum Support)	1	88-Up	73630G	80902
668D	Rear Support (3.45" Bearing Design)	1	92-93	73668B	80935A
668D	Rear Support (3.45" Bushing Design)	1	93-Up	73668H	80935B
SPRAGS					
656F	Forward Sprag	1	88-Up	73656G	78940A
658G	Low Sprag	1	88-Up	73658Q	78960A
VALVE BODIES					
740H	Valve Body (Premium) (JR403E)	1	90-Up	73740-5	P80990
740H	Valve Body (5 Solenoids) (RE4R03A)	1	90-Up	73740Q	78990E
MISCELLANEOUS COMPONENTS					
902	Piston, 4th Servo (Upgrade)	1	88-Up	73902K	80528
915	Strut, Servo Band (Upgrade)	1	88-Up	73915-2	78932

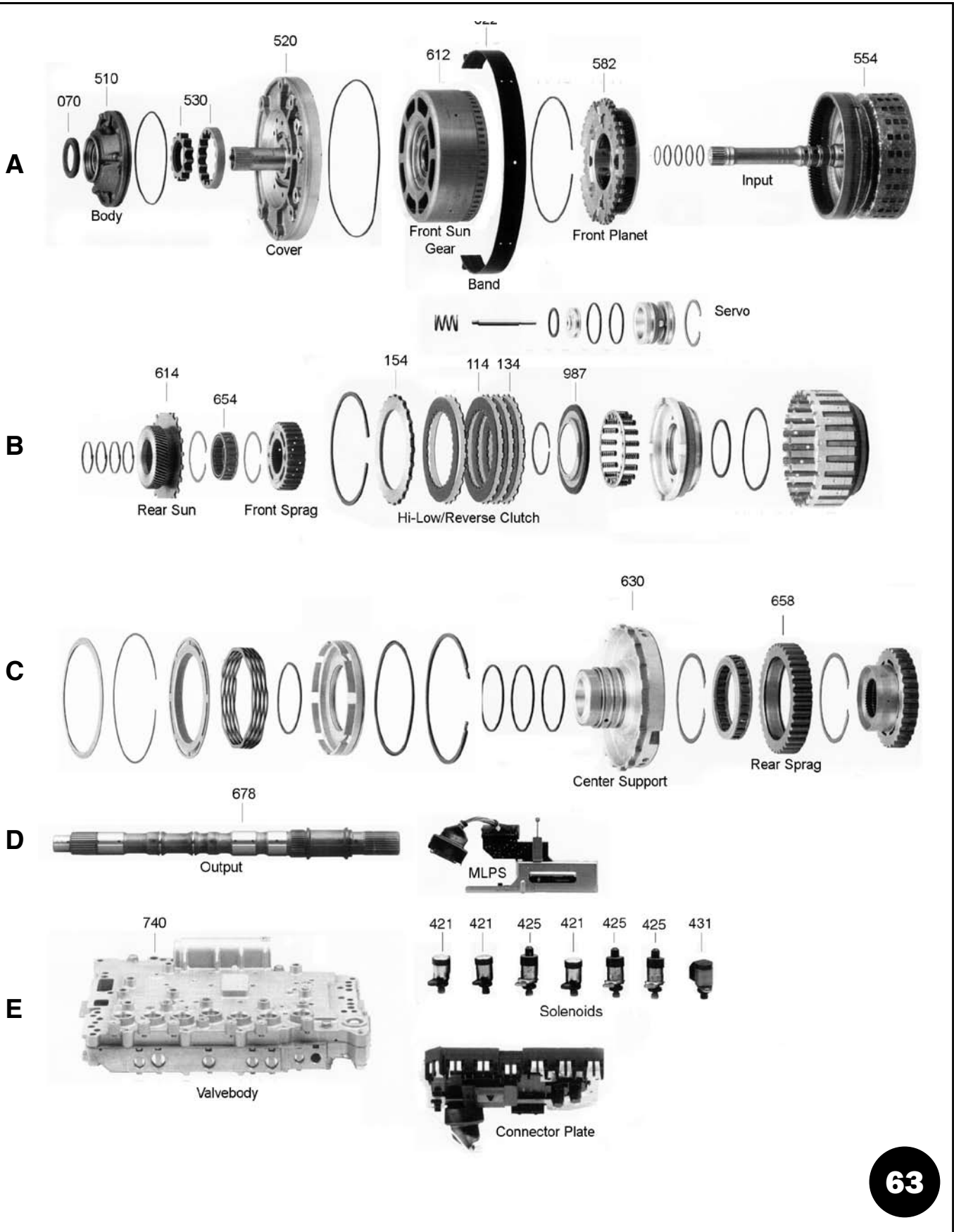



F

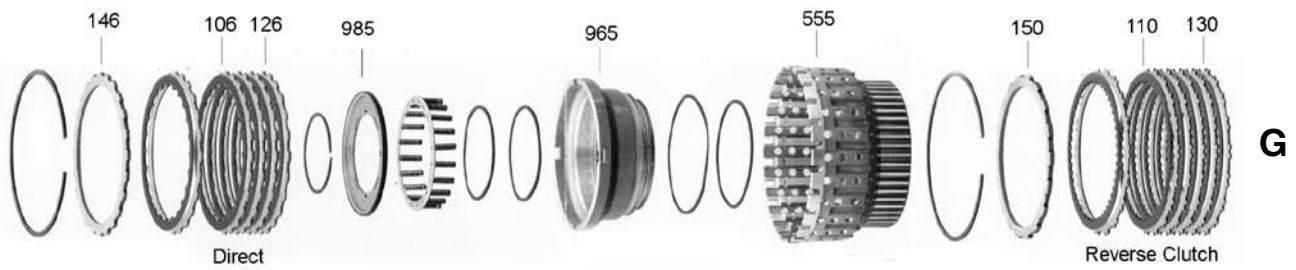

G

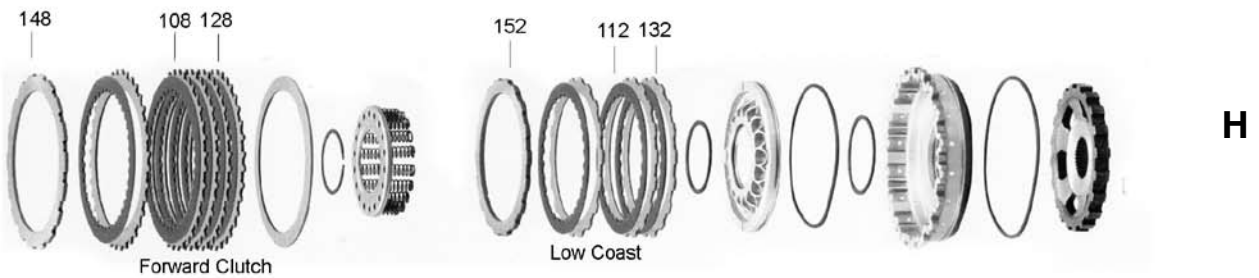

H

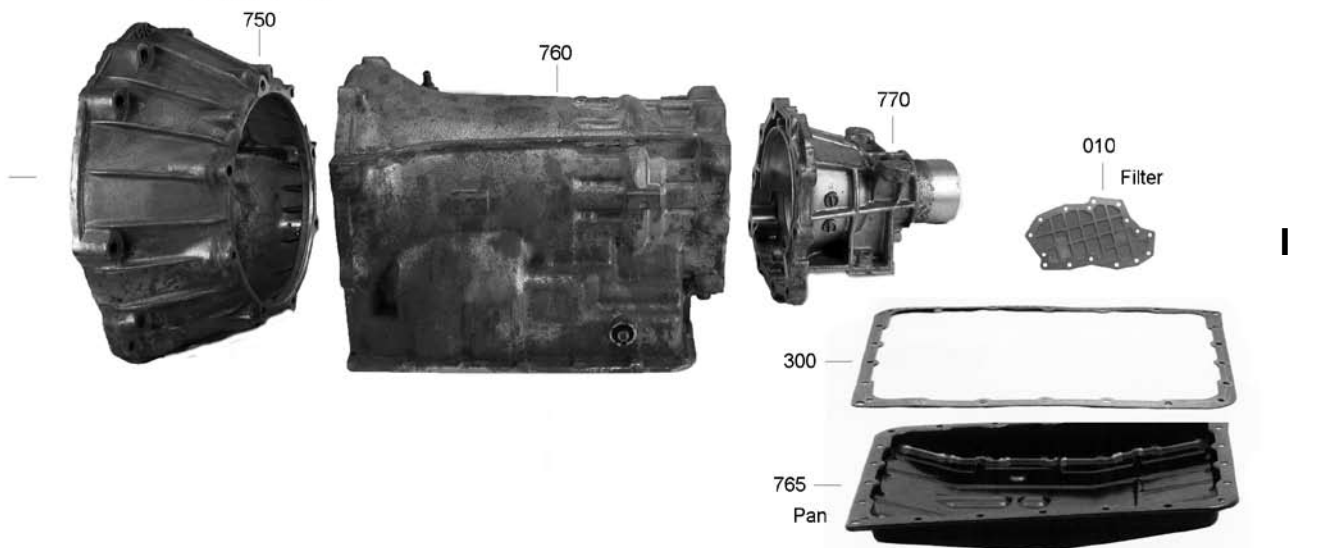

I

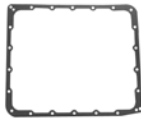

Infiniti 02-Up
Nissan 03-Up



63010

ILL.	DESCRIPTION	QTY.	YEAR	PART NO.	REFERENCE NO.
MASTER OVERHAUL KITS (WITH STEELS)					
006	RE5R05A (Exc. Titan, Armada, QX56) (w/ 50 T Reverse Friction).....	1	02-Up	63006	K9300
006	RE5R05A (Titan, Armada, QX56) (w/ 40 T Reverse Friction)	1	02-Up	63006A	K9300A
LESS STEEL KITS					
004	RE5R05A (Exc. Titan, Armada, QX56) (w/ 50 T Reverse Friction).....	1	02-Up	63004	K9300-LS
004	RE5R05A (Titan, Armada, QX56) (w/ 40 T Reverse Friction)	1	02-Up	63004A	K9300A-LS
OVERHAUL KITS (W/ RINGS & SEALS)					
002	RE5R05A.....	1	02-Up	63002	K93900
FILTER KITS					
011	Filter Kit, RE5R05A.....	1	02-Up	63011	FK93800
FILTERS					
010	Filter, RE5R05A.....	1	02-Up	63010	93800
BANDS					
Prefix Key: B = Borg Warner, A = OEM (Exc. BW), N = All Other New, R = Relined					
020	Band, 3-5.....	1	02-Up	63020	93700
METAL CLAD SEALS					
070	Converter (Front)	1	02-Up	93070	68200
074	Rear (2wd)	1	02-Up	73074D	78203
074	Rear (4wd)	1	02-Up	63074	N/A
FRICTION PLATES					
100	Input.....	7	02-Up	63100	93100
106	Direct.....	6	02-Up	63106	93104
108	Forward	5	02-Up	63108	93108
110	Reverse (40 T) (Titan, Armada, QX56).....	7	03-Up	63110A	93108A
110	Reverse (50 T) (Exc Titan, Armada, QX56)	6	02-Up	63110	93106
112	Low Coast	3	02-Up	63112	93110
114	High & Low/ Reverse	5	02-Up	63114	93102
STEEL PLATES					
120	Input.....	7	02-Up	63120	93101
126	Direct.....	6	02-Up	63126	93105
128	Forward (18 Wide Teeth) (Exc Titan, Armada, QX56).....	5	02-Up	63128	93109
128	Forward (16 Narrow Teeth) (Titan, Armada, QX56)	5	02-Up	63128A	93109A
130	Reverse (.063") (Titan, Armada, QX56).....	7	02-Up	63130A	93107A
130	Reverse (.079") (Exc Titan, Armada, QX56)	6	02-Up	63130	93107
132	Low Coast (18 Wide Teeth) (Exc Titan, Armada, QX56).....	3	02-Up	63132	93111
132	Low Coast (15 Narrow Teeth) (Titan, Armada, QX56).....	3	02-Up	63132A	93111A
134	High & Low/ Reverse	5	02-Up	63134	93103
GASKETS & O-RINGS					
300	Gasket, Pan.....	1	02-Up	63300	13809F
ELECTRICAL COMPONENTS					
410	Switch, MLPS	1	02-Up	63410	15A-431
421	Solenoid, On / Off (# 260 130 031)	3	02-Up	63421	5A-432
425	Solenoid, PWM w/ Cap (# 260 130 030).....	3	02-Up	63425	5A-431
431	Solenoid, EPC (Low OHM)	1	02-Up	63431B	5A-430B

ILL.	DESCRIPTION	QTY.	YEAR	PART NO.	REFERENCE NO.
ELECTRICAL COMPONENTS (Cont.)					
431	Solenoid, EPC (High OHM) (# 260 120 042)	1	02-Up	63431A	5A-430
436	Sensor, Output Speed.....	1	02-Up	63436	20A-431
437	Sensor, TOT	1	02-Up	63437	20A-432
438	Sensor, Input Speed (w/ Press Manifold Switch)	1	02-Up	63438	15A-432
445	Connector, Case (w/ Harness) (3 External Plugs).....	1	02-Up	63445	25A-431
HARD PARTS					
Prefix Key: D = OEM, A = Aftermarket New, R = Remanufactured					
MISCELLANEOUS HARD PARTS					
510A	Pump Body (All Exc Pathfinder)	1	02-Up	63510	N/A
520A	Pump Cover (Car)	1	02-Up	63520	N/A
520A	Pump Cover (Truck Exc Pathfinder)	1	02-Up	63520A	N/A
554A	Drum, Input (Car Q Series Only)	1	02-Up	63554	N/A
554A	Drum, Input (Truck Exc Pathfinder)	1	02-Up	63554A	N/A
582A	Planet, Front (Car)	1	02-Up	63582	N/A
582A	Planet, Front (Truck Exc Pathfinder)	1	02-Up	63582A	N/A
584F	Planet, Rear (Car).....	1	02-Up	63584	N/A
584F	Planet, Rear (Truck Exc Pathfinder).....	1	02-Up	63584A	N/A
586F	Planet, Center (Car).....	1	02-Up	63586	N/A
586F	Planet, Center (Truck Exc Pathfinder).....	1	02-Up	63586A	N/A
594A	Ring Gear, Rear Planet (Car)	1	02-Up	63594	N/A
594A	Ring Gear, Rear (Truck Exc Pathfinder)	1	02-Up	63594A	N/A
612A	Sun Gear, Front (Car).....	1	02-Up	63612	N/A
612A	Sun Gear, Front (Truck Exc Pathfinder).....	1	02-Up	63612A	N/A
614B	Sun Gear, Rear (Car)	1	02-Up	63614	N/A
614B	Sun Gear, Rear (Truck Exc Pathfinder)	1	02-Up	63614A	N/A
616F	Sun Gear, Center (Car)	1	02-Up	63616	N/A
616F	Sun Gear, Center (Truck Exc Pathfinder).....	1	02-Up	63616A	N/A
630C	Center Support (All Truck).....	1	02-Up	63630A	N/A
654B	Sprag , Input (Front)	1	02-Up	63654	N/A
658C	Sprag , Forward (Rear)	1	02-Up	63658	N/A
984F	Piston Retainer, Input (Bonded)	1	02-Up	63984	N/A
985G	Piston Retainer, Direct (Bonded)	1	02-Up	63985	N/A
987B	Piston Retainer, Hi-Low/Reverse (Bonded).....	1	02-Up	63987	N/A
NOTES					

RE5R05A