

CHRYSLER FWD A604

(40TE, 41TE - FWD, 41AE - AWD)

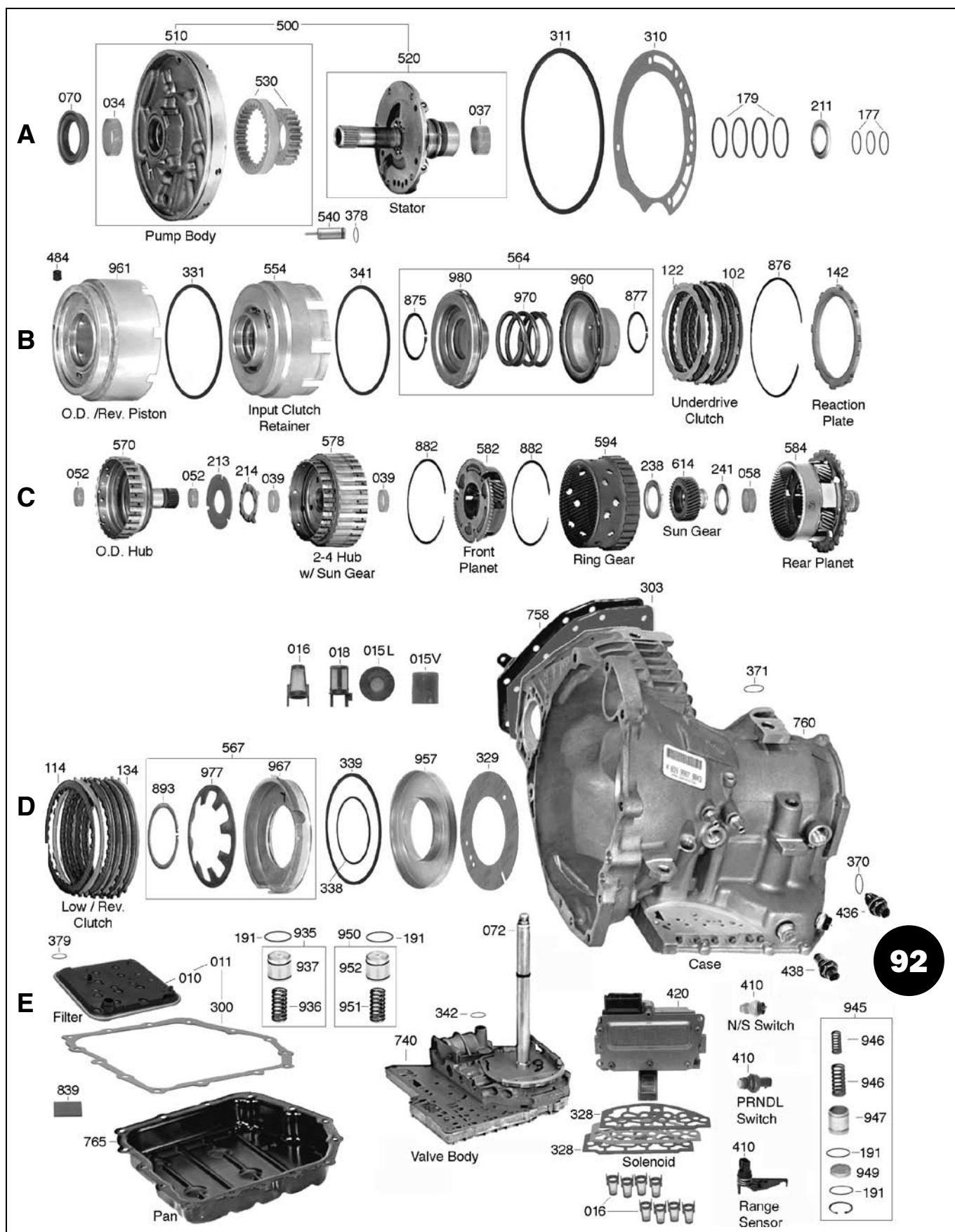

CHRYSLER FWD A604

(40TE, 41TE - FWD, 41AE - AWD)

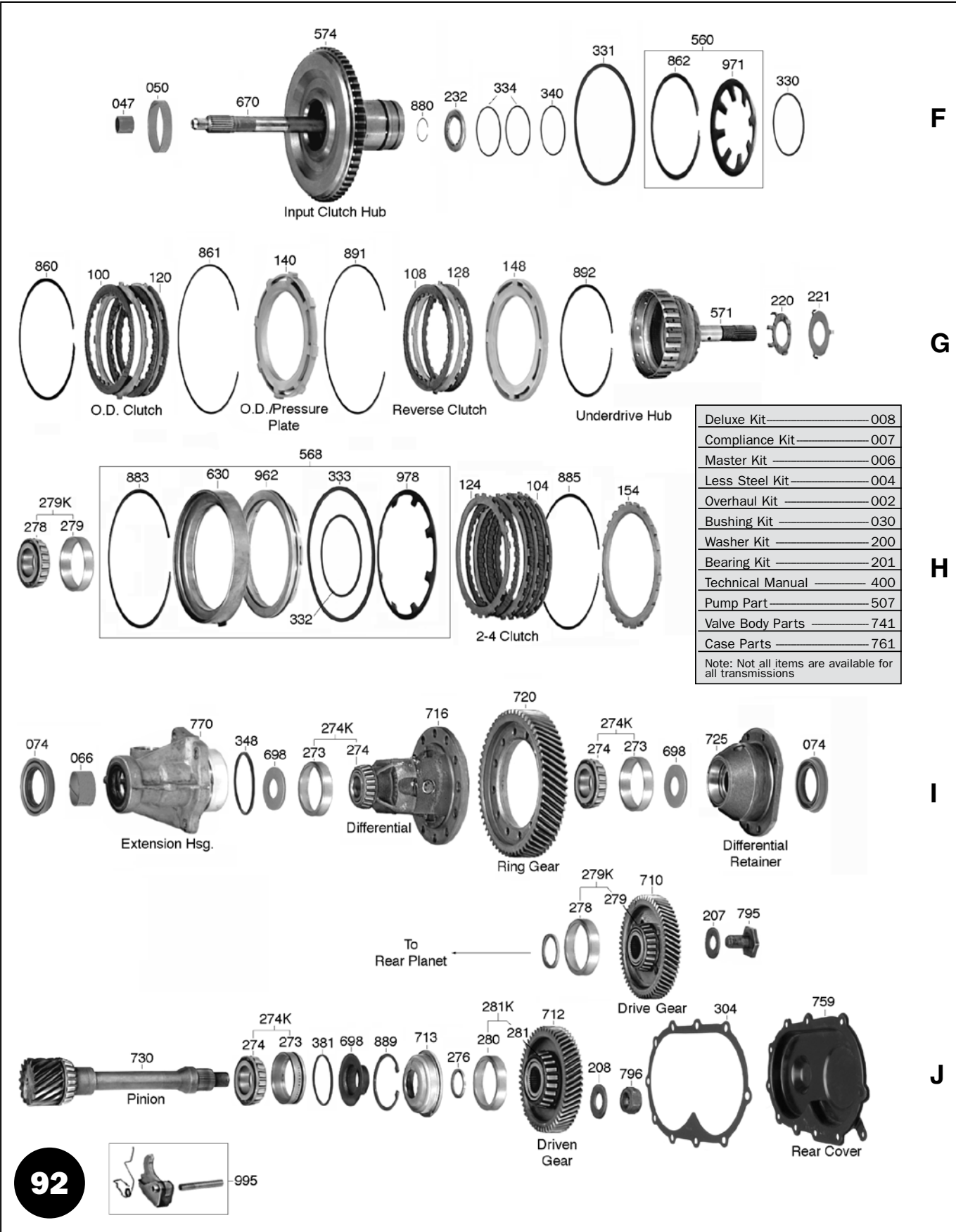

F

G

H

I

J

A604

CHRYSLER FWD A606 (42LE)

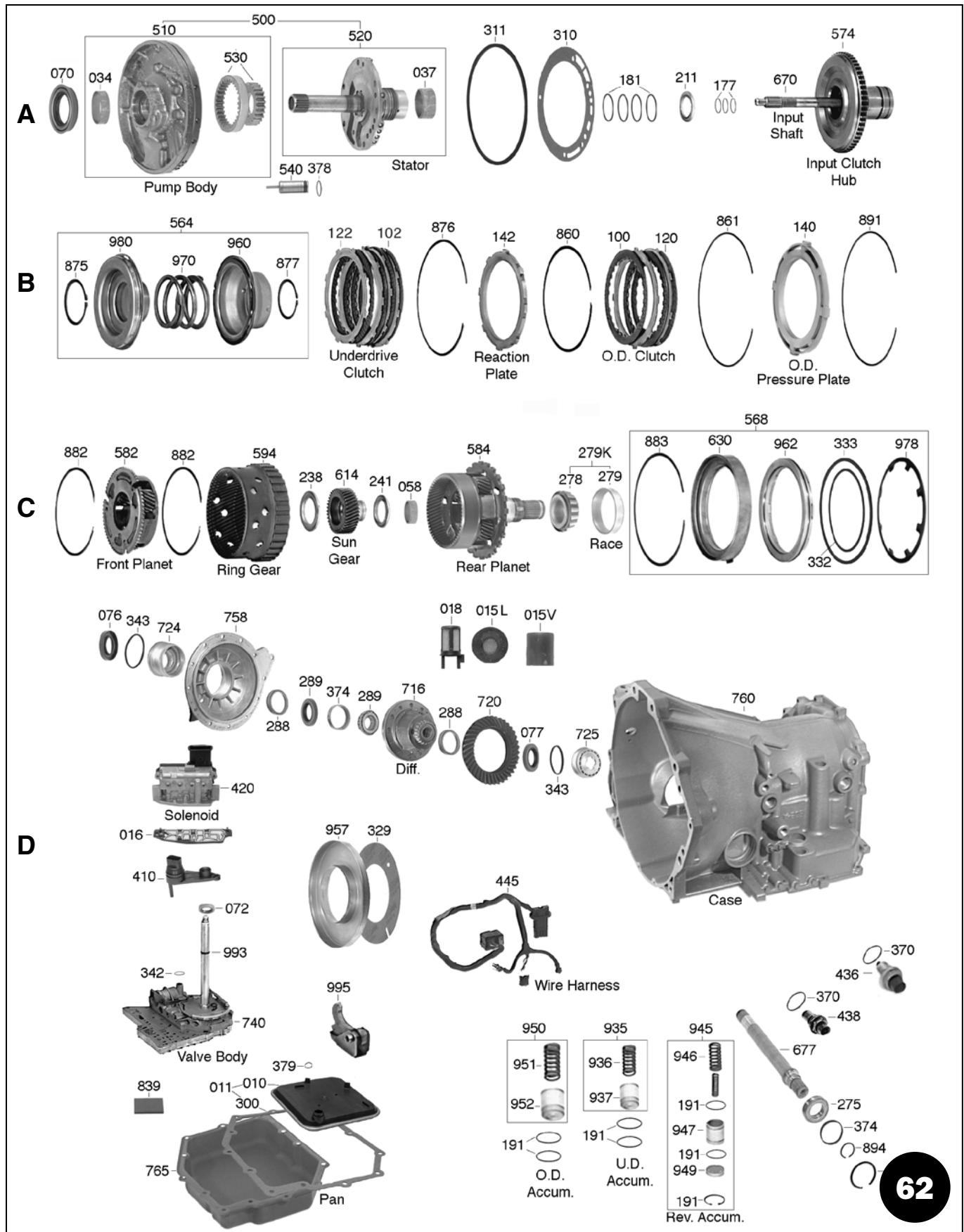

CHRYSLER FWD A606 (42LE)

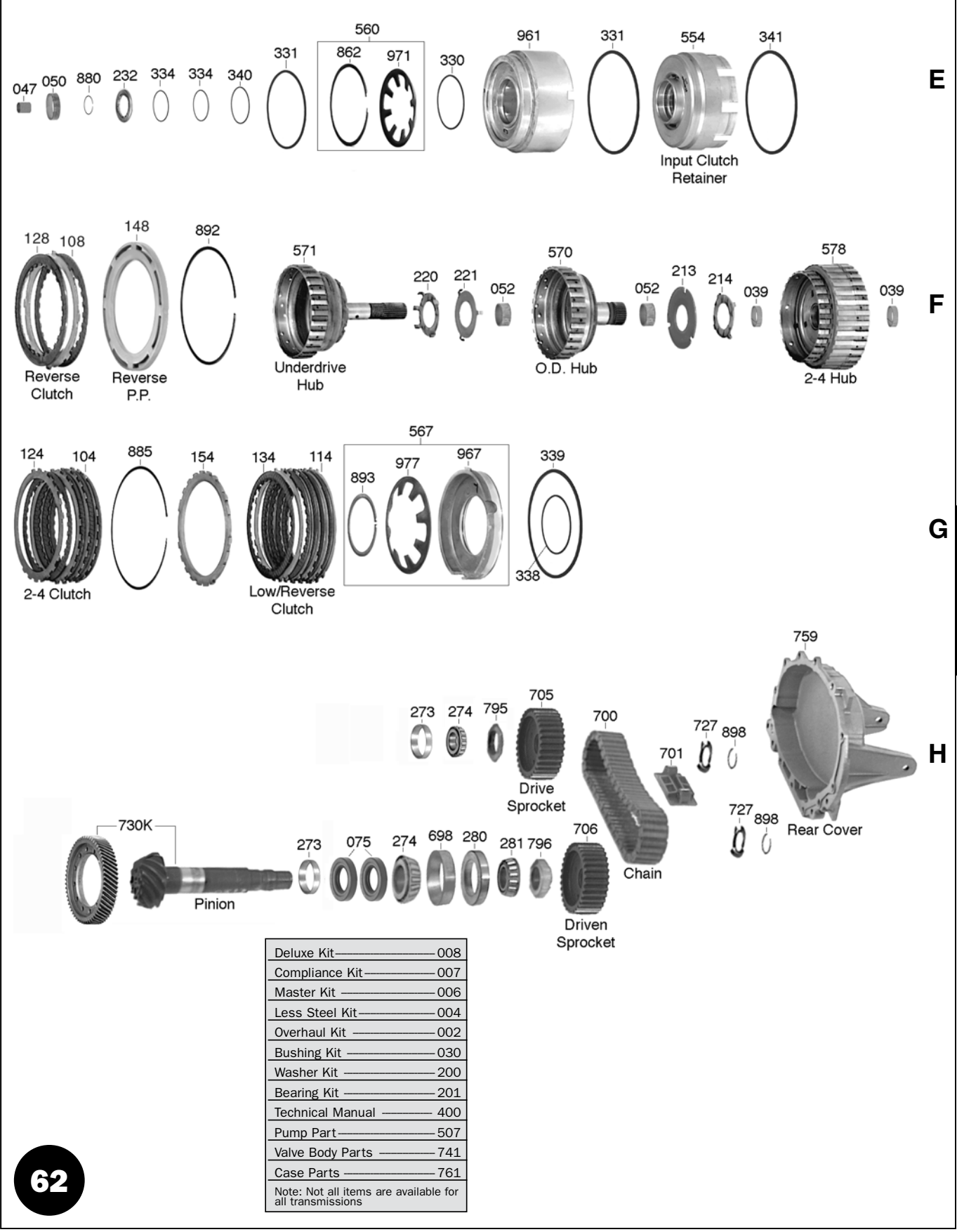

CHRYSLER FWD A604

(40TE, 41TE - FWD, 41AE - AWD)

A606

(42LE)

42RLE

(Rwd)

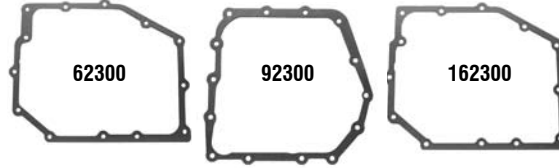
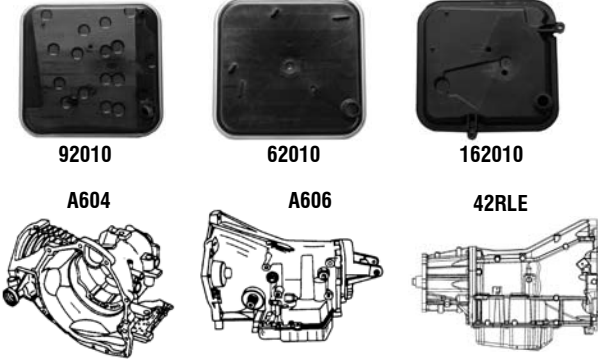

NOTE: A604 is 41TE and 41AE AWD. 40TE is a light-duty version of A604. All are transverse. A606 is 42LE FWD inline. 42RLE is RWD and equivalent to A606.
Use A604 Illustration Pages

ILL.	DESCRIPTION	QTY.	YEAR	PART NO.	REFERENCE NO.
DELUXE KITS (SUPER KITS) (1)					
008H	A604, 40TE, 41TE (2).....	1	90-03	92008AX	K7200-R
008H	A604, 40TE, 41TE (w/ Hi-Energy Frictions).....	1	90-03	92008BX	K7200H-R
008H	40TE (A604).....	1	04-Up	92008DX	K7200D-R
008H	41TE (A604).....	1	04-Up	92008CX	K7200B-R
008H	A606 (42LE).....	1	93-Up	62008X	K7200A-R
008H	42RLE (Rwd).....	1	03-Up	162008	K7200M-R
COMPLIANCE KITS (CALIFORNIA KITS) (1)					
007H	A604, 40TE, 41TE (2).....	1	90-03	92007AX	CK7200-R
007H	A604, 40TE, 41TE (w/ Hi-Energy Frictions).....	1	90-03	92007BX	CK7200H-R
007H	40TE (A604).....	1	04-Up	92007DX	CK7200D-R
007H	41TE (A604).....	1	04-Up	92007CX	CK7200B-R
007H	A606 (42LE).....	1	93-Up	62007X	CK7200A-R
007H	42RLE.....	1	03-Up	162007	CK7200M-R
MASTER OVERHAUL KITS (WITH STEELS) (1)					
006H	A604, 40TE, 41TE (2).....	1	90-03	92006AX	K7200
006H	A604, 40TE, 41TE (w/ Hi-Energy Frictions).....	1	90-03	92006BX	K7200H
006H	40TE (A604).....	1	04-Up	92006DX	K7200D
006H	41TE (A604).....	1	04-Up	92006CX	K7200B
006H	A606 (42LE).....	1	93-Up	62006X	K7200A
006H	42RLE.....	1	03-Up	162006	K7200M
LESS STEEL KITS (1)					
004H	A604, 40TE, 41TE (2).....	1	90-03	92004AX	K7200-LS
004H	A604, 40TE, 41TE (w/ Hi-Energy Frictions).....	1	90-03	92004BX	K7200H-LS
004H	40TE (A604).....	1	04-Up	92004DX	K7200D-LS
004H	41TE (A604).....	1	04-Up	92004CX	K7200B-LS
004H	A606 (42LE).....	1	93-Up	62004X	K7200A-LS
004H	42RLE.....	1	03-Up	162004	K7200M-LS
OVERHAUL KITS (W/ RINGS & SEALS) (1)					
002H	A604, 40TE, 41TE.....	1	89-03	92002X	K72900
002H	40TE, 41TE (A604).....	1	04-Up	92002AX	K72900B
002H	A606 (42LE).....	1	93-Up	62002X	K72900A
002H	42RLE.....	1	03-Up	162002	K72900M
GASKET & SEAL KITS (W/O RINGS & SEALS) (1)					
000H	A604, 40TE, 41TE.....	1	89-03	92000X	K72900-1
000H	A606 (42LE).....	1	93-Up	62000X	K72900A-1
<p>(1) - "X" suffix kits don't incl Pan Gaskets, Kits w/ Fiber Gaskets, use an "F" suffix. (2) - To Service 1989 kits, order (3) 92100 Frictions & (2) 92120A Steels</p>					

ILL.	DESCRIPTION	QTY.	YEAR	PART NO.	REFERENCE NO.
FILTER KITS					
011E	Filter Kit, A604, 40TE	1	89-Up	92011	FK72776
011E	Filter Kit, A606	1	93-Up	62011	FK72776A
011E	Filter Kit, 42RLE	1	03-Up	162011	FK72776M
FILTERS					
010E	Filter, A604, 40TE.....	1	89-Up	92010	72776
010E	Filter, A606.....	1	93-Up	62010	72776A
01E	Filter, 42RLE.....	1	03-Up	162010	72776M
015D	Screen, Overdrive Piston	1	89-Up	32015	72712
015D	Screen, Low/ Reverse Piston.....	1	89-Up	92015	72712A
016D	Screen, Solenoid (A604)	8	89-99	92016	72712B
016D	Screen, Solenoid (A604)	8	00-Up	92016A	72712C
016D	Screen, Solenoid (A606).....	1	93-Up	62016	72713
016D	Screen, Solenoid (42RLE)	1	03-Up	162016	72713A
018D	Screen, Valve Body Regulator Feed.....	1	89-Up	12018	48713
BUSHINGS					
030H	Bushing Kit	1	89-95	92030A	K72901
030H	Bushing Kit	1	96-Up	92030B	K72901A
034A	Pump Body, Babbitt.....	1	89-Up	12034	12502
034A	Pump Body, Tighter Tolerance	1	89-Up	S12034	N/A
034A	Pump Body, Bronze.....	1	89-Up	12034A	12502A
039C	2-4 Clutch Hub (1.155" ID)	1	89-95	92039	72005
039C	2-4 Clutch Hub (1.170" ID)	1	96-Up	92039A	72005A
047F	Input Shaft (Rear) (.590" OD) (01-Up, .604" OD Use 92047A).....	1	89-00	92047	72002
050F	Input Clutch Hub (Front)	1	89-Up	92050	72003
050F	Input Clutch Hub (Front) 41TE, 42LE Tighter Tolerances (req T-92003-TL)	1	89-Up	S92050	N/A
052C	Overdrive Clutch Hub (.365" Tall)	1	89-95	92052	72004
052C	Overdrive Clutch Hub (Replaces Both Bushings) 1.142" OD Shaft.....	1	89-95	S92052E	72004X
052C	Overdrive Clutch Hub (.283" Tall)	1	96-Up	92052A	72004A
052C	Overdrive Clutch Hub (Replaces Both Bushings) 1.162" OD Shaft.....	1	96-Up	S92052EA	72004AX
058C	Rear Planet	1	89-Up	92058	72006
066I	Extension Housing	1	89-Up	32066	48501
063	Differential Housing (Inner) (A606)	2	93-Up	62063	72008
METAL CLAD SEALS					
070A	Front Pump (All).....	1	89-Up	12070	12575
072D	Linkage (Valve Body Stem Seal) Rubber (A606).....	1	93-Up	92072	N/A
074I	Rear 2wd (w/o Boot) (42RLE)	1	03-Up	36074	4743C
074I	Rear 2wd (w/ Boot) (42RLE)	1	03-Up	36074B	16695C
074I	Rear 4wd (Adapter Housing) (42RLE).....	1	03-Up	12074J	12925F
074I	Awd Transfer Case (Case Adapter)	2	91-Up	92074A	72205
074I	Awd Transfer Case (Outer Half Shaft Cover Seal)	1	91-Up	32076	48576A
075	Transfer Shaft (Small) w/ 12 Indentions (A606)	1	93-Up	62075	72213
075	Transfer Shaft (Large) Smooth (A606).....	1	93-Up	62075A	72212
076	Axle (Both Sides) (A604) (Repl # 32074)	2	89-Up	32076	48576A
076	Right Axle (Outer Differential Adjuster) (A606)	1	93-Up	62076	72210
077	Left Axle (Inner Differential Adjuster) (A606)	1	93-Up	62077	72211
076	Axle Stabilizer Seal (Fits T32275)	1	89-Up	T32076	48731BS
275	Support Bearing, Axle Stabilizer (Teckpak)	1	89-Up	T32275	48731B
FRICTION PLATES					
100G	Overdrive (.085")	3	1989	92100	72740A
100G	Overdrive (.073") (Hi-Energy) (All)	3-4	90-Up	92100B	72740H
100G	OD, UD, Reverse (Hi Performance) (Blue).....	AR	90-Up	R92100BHP	72740X

ILL.	DESCRIPTION	QTY.	YEAR	PART NO.	REFERENCE NO.
FRICITION PLATES (Cont.)					
102B	Underdrive	4	90-03	92100A	72740
102B	Underdrive (Hi-Energy) (All)	3-4	90-Up	92100B	72740H
104H	2-4 Clutch.....	4	89-03	92104A	72750
104H	2-4 Clutch (Hi-Energy) (All).....	3-4	90-Up	92104	72750H
104H	2-4 Clutch (Hi Performance) (Blue)	AR	89-Up	R92104HP	72750X
108G	Reverse	2	89-03	92100A	72740
108G	Reverse (Hi-Energy) (All).....	2	90-Up	92100B	72740H
114D	Low/ Reverse (Hi-Energy) (All).....	4-5	89-Up	92114	72760H
114D	Low/ Reverse (Hi Performance) (Blue)	AR	89-Up	R92114HP	72760X
N.I.	OD, UD, Reverse (Hi Performance) (Blue).....	AR	90-Up	R92100BHP	72740X
N.I.	Friction & Steel Kit, Overdrive "Power Pack" (Red Eagle).....	AR	89-Up	A92100HPK	K72-72
N.I.	Fiction & Steel Kit, Low/ Reverse Case Saver.....	AR	89-Up	92114PK	N/A
STEEL PLATES					
120G	Overdrive (.100").....	2	1989	92120A	72741A
120G	Overdrive (.068") (All)	3	90-Up	92120	72741
122B	Underdrive (All)	4	89-Up	92120	72741
124H	2-4 Clutch (All)	3-4	89-Up	92124	72751
128G	Reverse (All)	1	89-Up	92120	72741
134D	Low/ Reverse (All)	4-5	89-Up	92134	72761
139	Steel Module (All).....	1	90-Up	92139A	N/A
PRESSURE PLATES					
Prefix Key: D = OEM, A = Aftermarket New, R = Remanufactured					
140G	Overdrive Clutch (4 Lug) (.340") (Exc 40TE)	1	L90-Up	92140A	72564R
140G	Overdrive Clutch (4 Lug) (.480") (40TE).....	1	03-Up	92140B	72564T
142B	Underdrive Kit w/ Snap Ring (.236")	1	89-96	92142BK	K72564J
142B	Underdrive Kit w/ Snap Ring (.255")	1	89-96	92142CK	K72564K
142B	Underdrive Kit w/ Snap Ring (.275")	1	89-96	92142DK	K72564L
142B	Underdrive Kit w/ Snap Ring (.248")	1	97-Up	92142EAK	K72564N
142B	Underdrive Kit w/ Snap Ring (.268")	1	97-Up	92142EBK	K72564P
142B	Underdrive Kit w/ Snap Ring (.245")	1	97-Up	92142EK	K72564M
150G	Reverse (Exc 40TE).....	1	93-Up	92150B	72564
150G	Reverse (40TE).....	1	03-Up	92150	72564T
154H	Low/ Reverse Kit w/ Snap Ring (.210")	1	89-Up	92154K	72565
154H	Low/ Reverse Kit w/ Snap Ring (.220")	1	89-Up	92154AK	N/A
154H	Low/ Reverse Kit w/ Snap Ring (.230")	1	89-Up	92154BK	K72565
154H	Low/ Reverse Kit w/ Snap Ring (.240")	1	89-Up	92154CK	K72565C
154H	Low/ Reverse Kit w/ Snap Ring (.250")	1	89-Up	92154DK	N/A
154H	Low/ Reverse Kit w/ Snap Ring (.260")	1	89-Up	92154EK	N/A
154H	Low/ Reverse Kit w/ Snap Ring (.270")	1	89-Up	92154FK	K72565F
VALVE BODY RECALIBRATION KITS					
165H	Shift Kit®, 604, 606, 42LE, 40 & 41TE, 41AE (Transgo®)	1	89-Up	T92165	K72908J
165H	Sure Cure Kit (A604) (Sonnax).....	1	89-Up	S92174	72S01
SEALING RINGS					
175H	Ring Kit.....	1	89-Up	92175	K72950
175H	Ring Kit, Accumulator (8) & Stator Ring (4) only.....	1	89-Up	92191K	K72900-3
177A	Input Shaft 1.443" OD (Teflon)	3	89-Up	92177T	72301T
179A	Stator Support (Seal Plated)	4	89-Up	12179A	12600A
179A	Stator Support (Teflon)	4	89-Up	92181T	34407T
191E	Accumulator (Non-Rotating) 1.013" OD (Graphite)	8	89-Up	92191	N/A
191E	Accumulator 1.013" OD (Teflon).....	8	89-Up	92191T	72308T

ILL.	DESCRIPTION	QTY.	YEAR	PART NO.	REFERENCE NO.
THRUST WASHERS					
200H	Washer Kit (92221K, 92214 & 4 Selectives).....	1	89-Up	92200	N/A
200H	Washer Kit (92221K, 92214, 92213F).....	1	89-Up	92200A	N/A
200H	Washer Kit (92220 & 92214).....	1	89-Up	92200B	K72400
214C	Washer, Overdrive Hub to 2-4 Hub (4 Tab).....	1	89-Up	92214	72402
220G	Washer, Underdrive Hub to Overdrive Hub (5 Tab).....	1	89-Up	92220	72400
BEARINGS & RACES					
201H	Bearing Kit.....	1	89-Up	92201A	K72400B
211A	Bearing, Stator to Input Drum.....	1	89-Up	92211	72410
213C	Race, Overdrive Hub to 2-4 Hub (3 Slot) .048".....	1	89-Up	92213A	72449
213C	Race, Overdrive Hub to 2-4 Hub (3 Slot) .057".....	1	89-Up	92213B	N/A
213C	Race, Overdrive Hub to 2-4 Hub (3 Slot) .066".....	1	89-Up	92213C	72449A
213C	Race, Overdrive Hub to 2-4 Hub (3 Slot) .074".....	1	89-Up	92213D	N/A
213C	Race, Overdrive Hub to 2-4 Hub (3 Slot) .083".....	1	89-Up	92213E	72449B
213C	Race, Overdrive Hub to 2-4 Hub (3 Slot) .091".....	1	89-Up	92213F	N/A
213C	Race, Overdrive Hub to 2-4 Hub (3 Slot) .100".....	1	89-Up	92213G	72449C
213C	Race, Overdrive Hub to 2-4 Hub (3 Slot) .109".....	1	89-Up	92213H	N/A
213C	Race, Overdrive Hub to 2-4 Hub (3 Slot) .117".....	1	89-Up	92213HA	72449D
213C	Race, Overdrive Hub to 2-4 Hub (3 Slot) .126".....	1	89-Up	92213J	N/A
221G	Race & Washer Kit, Input Drum to Underdrive Hub.....	1	89-Up	92221K	N/A
232F	Bearing, Input Drum to Underdrive Hub.....	1	89-Up	92232	72411A
238C	Bearing, Front Planet to Rear Sun Gear.....	1	89-Up	92238	72412
241C	Bearing, Rear Sun Gear to Rear Planet.....	1	89-Up	92232	72411A
255	Cup Race, Driven Transfer Gear to Case.....	1	89-Up	32255	48768
273I	Cup Race, Pinion to Case (A604).....	1	89-Up	92273	N/A
273I	Cup Race, Pinion to Case (A606).....	1	93-Up	62273	72974
274I	Bearing, Pinion to Case (A604).....	1	89-Up	92274	48761T
274I	Bearing, Pinion to Case (A606).....	1	93-95	62274	72977
274I	Bearing, Differential (Ring Gear Side) (All Wheel Drive) (19 Rollers).....	1	96-Up	92274A	48761BT
274I	Bearing & Race Kit, Pinion to Case.....	1	89-Up	92274K	K72965
274I	Bearing & Race Kit, Differential (Both Sides) & Rear Planet (Exc Below).....	1	89-Up	32274K	N/A
274I	Bearing & Race Kit, Differential (Left Side).....	1	L95-Up	32274AK	N/A
274I	Bearing & Race Kit, Differential (AWD) (Right Side).....	1	91-Up	92274BK	N/A
275D	Ball Bearing, Axle Shaft to Case (Enclosed Sealed Type) (A606).....	1	93-Up	62275	72972
275D	Support Bearing, Axle Stabilizer (Teckpak).....	1	89-Up	T32275	48731B
276	Bearing, Transfer Shaft (Rear) (A606).....	1	93-95	62276	72975
278J	Cup Race, Output Gear Bearing to Case.....	1	89-Up	92278	72963
279J	Bearing, Output Gear.....	1	89-Up	92279	72964
279J	Bearing and Race Kit, Presses on Transfer Drive Gear.....	1	89-Up	92279K	N/A
280J	Cup Race, Driven Transfer Gear to Case.....	1	89-Up	92280	72967
281J	Bearing, Presses on Driven Transfer Gear.....	1	89-Up	92281	72968
281J	Bearing & Race Kit, Driven Transfer Gear to Case.....	1	89-Up	32274K	N/A
289	Bearing, Differential Housing to Retainer (A606).....	2	93-Up	62289	72961
SHIM KITS					
276	Shim Kit, Transfer Shaft (.005") (10 Per Kit).....	1	89-Up	92276AK	K72953
276	Shim Kit, Transfer Shaft (.030") (10 Per Kit).....	1	89-Up	92276BK	N/A
276	Shim Kit, Transfer Shaft (.037") (10 Per Kit).....	1	89-Up	92276CK	N/A
276	Shim Kit, Transfer Shaft (.045") (10 Per Kit).....	1	89-Up	92276DK	N/A
293	Shim Kit, Differential (.005") (10 Per Kit).....	1	78-Up	92293AK	K48955
GASKETS & O-RINGS					
300E	Gasket, Bottom Pan (Cork) (A604, 40TE).....	1	89-Up	92300	13986X
300E	Gasket, Bottom Pan (Fiber) (A604, 40TE).....	1	89-Up	92300F	13986F
300E	Gasket, Bottom Pan (Cork) (A606).....	1	93-Up	62300	13986AX
300E	Gasket, Bottom Pan (Fiber) (A606).....	1	93-Up	62300F	13986AF

ILL.	DESCRIPTION	QTY.	YEAR	PART NO.	REFERENCE NO.
GASKETS & O-RINGS (Cont.)					
300E	Gasket, Pan (Fiber) (42RLE).....	1	03-Up	162300F	13986BF
303D	Gasket, Differential Cover (Cork).....	1	89-Up	92303	13873
303D	Gasket, Differential Cover (Fiber).....	1	89-Up	92303F	N/A
304J	Gasket, Transfer Gear Cover (Cork).....	1	89-Up	92304	13874
304J	Gasket, Transfer Gear Cover (Fiber).....	1	89-Up	92304F	N/A
310A	Gasket, Pump (A604).....	1	89-Up	92310	13872
310A	Gasket, Pump (A606).....	1	93-Up	62310	13872A
311A	O-Ring, Front Pump.....	1	89-Up	92311	13721
328E	Gasket, Solenoid (Used w/ Separator Plate).....	2	89-E99	92328	13875
328E	Gasket, Solenoid (Used w/o Separator Plate).....	2	L89-Up	92328A	13875A
342E	Seal, 2nd-4th Clutch Feed (Valve Body to Case).....	1	89-Up	92342	N/A
348I	O-Ring, Extension Housing.....	1	89-Up	32348	13736
349	Seal, Manual Lever Sensor (604 96-98, 606 93-97).....	1	93-98	92349	13739
349	Seal, Manual Lever Sensor (604 99-Up, 606 98-Up).....	1	98-Up	92349A	13739A
349	Seal, Manual Lever Sensor (Retros All).....	1	98-Up	92349C	13739B
371D	O-Ring, Filler Tube.....	1	89-Up	44371A	3291L
379E	O-Ring, Filter.....	1	89-Up	92379	13876
TECHNICAL MANUALS					
400H	Tech Manual (A604).....	1	89-Up	92400	72Y01
400H	Tech Manual (A606).....	1	93-Up	62400	72Y03
400H	Tech Manual, Handbook (A604 1989-91 Updates).....	1	89-91	92400H	72Y02
400H	Tech Manual, ATRA Rebuild Procedures (A606, 41TE).....	1	93-Up	92400B	N/A
400H	Code Book, Diagnostic Codes (ATSG).....	1	89-Up	92400CB	72Y06
400H	Code Book, Diagnostic Codes (ATSG) Spanish.....	1	89-Up	92400CBS	72Y06S
ELECTRICAL COMPONENTS					
410E	Switch, Neutral Safety (External) (A604).....	1	1989	12410A	15A-627C
410E	Switch, Neutral Safety (External) (A604).....	1	90-95	92410	15A-627D
410E	Sensor, Range (PRNDL) (A604).....	1	1989	92410A	15A-629
410E	Sensor, Range (PRNDL) (A604).....	1	90-95	92410B	15A-629B
410E	Sensor, Range (Blade Terminals) (A606, Also 42RLE).....	1	98-Up	62410B	15A-634
410E	Sensor, MLPS Range and Neutral Safety (Round Pins) (A604).....	1	96-E98	92410C	15A-631
410E	Sensor, MLPS Range and Neutral Safety (Spades) (A604).....	1	L98-Up	92410D	15A-632
410E	Sensor, Neutral Safety (Manual Lever Position) (A606) (Replaces 7 & 9 Prong).....	1	93-97	62410A	15A-633
415	Switch, Pressure Transducer (41TES).....	1	07-Up	92415	15A-306
420E	Solenoid Pack (A604).....	1	89-Up	92420B	31A-100
420E	Solenoid Pack, Shift Control & Lock-Up (TCC) (A606).....	1	93-Up	62420	31A-100A
420	Solenoid Pack (42RLE).....	1	03-Up	162420	31A-100E
424	Repair Kit, Solenoid Block (If Original Solenoid Body).....	1	89-99	92424	K72900-4
424	Repair Kit, Solenoid Block (A604).....	1	00-Up	92424A	K72900A-4
424	Repair Kit, Solenoid Block (A606).....	1	93-Up	62424A	N/A
424	Repair Kit, Solenoid Block (Brass Contacts w/ Seals) (All).....	1	89-Up	92424B	K72900B-4
424	Repair Kit, Solenoid (42RLE).....	1	03-Up	162424	N/A
431	Solenoid, EPC (41TES).....	1	07-Up	92431	5A-306
436E	Sensor, Output Speed (VSS).....	1	89-Up	92436	20A-103
436E	Sensor, Output Speed (VSS) (42RLE).....	1	03-Up	162438	20A-426
438E	Sensor, Input Speed (TSS) (Exc 42RLE).....	1	89-Up	92438	20A-102
438E	Sensor, Input Speed (TSS) (42RLE).....	1	03-Up	72436	20A-420
444	Connector, EPC Solenoid (41TES).....	1	07-Up	92444	25A-306
445	Repair Kit, Wire Harness (A604).....	1	89-Up	92445AK	35A-200
445	Repair Kit, Wire Harness (A606).....	1	93-Up	62445AK	35R-200C
445	Repair Kit, Wire Harness (Input & Output Speed Sensor).....	1	89-Up	92445CK	35A-202
445	Repair Kit, Wire Harness (MLPS/ Range Sensor) (A604).....	1	E99-Up	92445BAK	35A-203A
445	Repair Kit, Wire Harness (MLPS/ Range Sensor) (A606).....	1	98-Up	92445BBK	35A-203C
500A	Pump (25 T Inner Gear) (3 Ring Stator) (A604).....	1	1989	92500A	72200

ILL.	DESCRIPTION	QTY.	YEAR	PART NO.	REFERENCE NO.
HARD PARTS					
Prefix Key: D = OEM, A = Aftermarket New, R = Remanufactured					
PUMPS					
500A	Pump (25 T Inner Gear) (4 Ring Stator) (A604)	1	89-98	92500B	72200A
500A	Pump (12 Lobe Inner Gear) (A604)	1	99-Up	92500C	72200B
500A	Pump (25 T Inner Gear) (A606).....	1	93-98	62500A	72200E
500A	Pump (12 Lobe Inner Gear) (A606)	1	99-Up	62500B	72200F
500A	Pump Assembly (12 Lobe Inner Gear) (42RLE)	1	03-Up	162500	72200D
510A	Pump Body (w/ Gears) (A604)	1	89-Up	92510	72202
510A	Pump Body (w/ Gears) (A606).....	1	93-Up	62510A	72202E
520A	Stator (Pump Cover) (4 Ring Type) (A604)	1	90-Up	92520A	72300A
520A	Stator (Pump Cover) (A606).....	1	93-Up	62520A	72300E
530A	Pump Gears (.708").....	1	89-Up	92530A	K72201
530A	Pump Gears (Oversized).....	1	93-Up	92530AA	K72201-OS
540A	Valve, Cooler Bypass (Pump) (OEM Style).....	1	89-Up	92540	72925
540A	Valve, Cooler Bypass (Pump) (Modified).....	1	89-Up	92761B-6	72925S
DRUMS & CLUTCH HUBS					
554B	Input Clutch Retainer (w/o Bevel) (All)	1	90-Up	92554A	72943
554B	Drum Kit, Input Clutch Retainer (w/o Bevel)	1	90-Up	92554AK	K72943
570C	Clutch Hub, Overdrive & Rev w/ Hollow Shaft (1.140" OD Shaft)	1	89-94	92570	72947
570C	Clutch Hub, Overdrive & Rev w/ Hollow Shaft (1.160" OD Shaft) (All)	1	95-Up	92570A	72947A
570C	Clutch Hub Kit, Overdrive- Updates 1.140" to 1.160" Diameter	1	89-Up	92570K	K72951A
571G	Clutch Hub, Underdrive w/ Solid Shaft (All)	1	89-Up	92571	72946
574F	Clutch Hub, Input Clutch (Cast-Iron) (For 3 Ring Stator) (A604)	1	1989	92574	N/A
574F	Clutch Hub, Input Clutch (Cast-Iron) (For 4 Ring Stator) (All).....	1	90-Up	92574A	72940
578C	Clutch Hub & Sun Gear, 2nd-4th Clutch (1.140" ID Bushing).....	1	89-95	92578	72948
578C	Clutch Hub & Sun Gear, 2nd-4th Clutch (1.160" ID Bushing) (All)	1	96-Up	92578A	72948A
567D	Piston Kit, Low/ Rev (Piston, Tin Housing, Spring, Snap Ring) (All).....	1	90-Up	92567A	N/A
568H	Piston Kit, 2nd-4th Clutch (Piston, Retainer) (All).....	1	89-Up	92568	N/A
PLANETS					
582C	Front (All).....	1	89-95	92582	N/A
582C	Front (Heat Treated Splines) (All)	1	96-Up	92582A	72951A
N.I.	Bearing, Below the Pinion Gears (if Front Planet is Disassembled).....	AR	89-Up	92232	72411A
584C	Rear (1" From Step to End of Shaft) (A604).....	1	89-E91	92584	72956
584C	Rear (1 1/8" From Step to End of Shaft) (A604).....	1	L91-95	92584A	72956A
584C	Rear (1 1/8" From Step to End of Shaft) (5 Pinion) (A604).....	1	96-Up	92584B	72956C
584C	Rear w/ Output Shaft (4 Pinion) (A606)	1	93-95	62584A	72956E
584C	Rear w/ Output Shaft (5 Pinion) (A606)	1	96-Up	62584B	72956E
584C	Planet, Rear (5 Gear) (.350" Parking Lug) (42RLE)	1	03-Up	162584	72956M
570C	Planet Kit, Front Planet, Overdrive, Rev Clutch Hub, 2-4 Clutch Hub w/ Sun Gear.....	1	89-Up	92570K	K72951A
582C	Planet Kit, Front w/ Ring Gear (All).....	1	89-95	92582K	72951
582C	Planet Kit, Front (Heat Treated Splines) (All)	1	96-Up	92582AK	72951A
583	Planet Kit, Front & Rear (A604).....	1	89-E91	92583	N/A
583	Planet Kit, Front & Rear (A604) (4 Gear)	1	L91-Up	92583A	K72930
583	Planet Kit, Front & Rear (A604) (5 Gear).....	1	L91-Up	92583B	N/A
583	Planet Kit, Front & Rear (A606).....	1	93-Up	62583A	N/A
584	Planet Kit, Rear (O/D Ratio 59 T / 54 T)	1	88-Up	92584K	K72956B
584	Planet Kit, Rear (U/D Ratio 47 T / 49 T)	1	03-Up	92584AK	K72956A
594C	Ring Gear, Rear Planet (All)	1	89-Up	92594	72952A
SUN GEARS					
614C	Sun Gear, Rear Planet (All)	1	89-Up	92614	72958

ILL.	DESCRIPTION	QTY.	YEAR	PART NO.	REFERENCE NO.
SHAFTS					
670F	Input Shaft (22 Spline)	1	89-Up	92670A	72731
670F	Input Shaft (24 Spline)	1	89-Up	92670B	72731A
670F	Input Shaft (A606, 42RLE)	1	93-Up	62670	72731E
677	Shaft, Axle (Goes Through Case) (A606)	1	93-Up	62677	72906E
678	Output Shaft (2wd) (12 7/8" Long) (42RLE)	1	03-Up	162678	N/A
678	Output Shaft (4wd) (7 1/8" Long) (42RLE)	1	03-Up	162678A	N/A
GEARS, OUTPUT & TRANSFER					
710J	Gear Kit, 59 T Output & 54 T Transfer (A604)	1	89-91	92710K	72960
710J	Gear Kit, 55 T Output & 58 T Transfer (A604)	1	89-91	92710AK	72960A
710J	Gear Kit, 50 T Output & 46 T Transfer (A604)	1	92-Up	92710BK	72960B
710J	Gear Kit, 47 T Output & 49 T Transfer (A604)	1	92-Up	92710FK	72960C
713J	Retainer, Transfer Gear Cup Race (Steel Housing) (A604)	1	89-Up	92713	72961A
CHAINS, SPROCKETS & SUPPORTS					
700	Chain (Single Wide) (A606)	1	93-94	62700A	72973
700	Chain (Dual Narrow) (A606)	1	95-Up	62700B	72973A
701	Chain Snubber, Rubber Faced For Double Chains (A606)	1	95-Up	62701C	N/A
701	Chain Kit, Dual Chain, Snubber & Sprockets (A606)	1	95-Up	62700BK	K72973A
705	Sprocket Set, 32 T Drive & 33 T Driven (Wide Chain Design) (A606)	1	93-94	62710AK	72960E
705	Sprocket Set, 32 T Drive & 33 T Driven (Narrow Chain Design) (A606)	1	95-Up	62710BK	72960F
DIFFERENTIALS					
716I	Differential Housing (A604) (Small ID)	1	89-95	92716	72980
716I	Differential Housing (A604) (Large ID)	1	95-Up	92716A	72980B
716D	Differential Housing, Less/Ring Gear (A606)	1	93-Up	62716A	72980E
730	Ring & Pinion Kit (A606)	1	93-Up	62730K	72970E
717J	Gear Kit, 12 Bolt (A604) (Side & Spider Gears w/ Washers & Pins)	1	89-Up	32717BK	N/A
717J	Shaft, Differential (For Spiders) w/ Clips (.660" Diameter) (A604) (OEM)	1	89-Up	D92717AK-3	K48785D
717J	Shaft, Differential (For Spiders) w/ Clips (.660" Diameter) (A604) (Superior)	1	89-Up	A92717AK-3	K48785
717J	Shaft, Differential (For Spiders) w/ Clips (.735" Diameter) (A604) (OEM)	1	89-Up	D92717BK-3	K48785E
717J	Shaft, Differential (For Spiders) w/ Clips (.735" Diameter) (A604) (Superior)	1	89-Up	A92717BK-3	K48785A
717J	Retainer Kit, Cross Shaft in Differential (2 Retainers) (A604)	1	89-Up	92717K	N/A
720I	Ring Gear, Differential (59 T) (A604)	1	89-Up	92720A	N/A
720I	Ring Gear, Differential (60 T) (A604)	1	89-Up	92720B	N/A
725I	Retainer, Differential (A604) (2wd) (Cast-Iron) 6 Bolt 2.477" Tall	1	89-Up	92725	72982
725I	Retainer, Differential (A604) (Awd) (Cast Iron) 6 Bolt 2.676" Tall	1	89-Up	92725B	N/A
725I	Retainer, Differential (A604) (Awd) (Steel) 6 Bolt	1	89-Up	92725C	N/A
727	Retainer, Transfer Gear Nut (A604)	2	95-Up	92727A	N/A
727	Plate, Transfer Gear Nut (Washer Under Nuts) (A604)	2	95-Up	92727B	N/A
730J	Pinion (Transfer Shaft) (17 T) (A604)	1	89-Up	92730A	N/A
730J	Ring & Pinion Set (Transfer Shaft) (59 T x 17 T) (A604)	1	89-Up	92730AK	72970A
730J	Pinion & Pinion Set (Transfer Shaft) (60 T x 16 T) (A604)	1	89-Up	92730BK	72970
698I	Baffle, Pinion Bearing (A604)	1	89-Up	92698	N/A
698I	Baffle, Differential Bearing (A604) (Under Axle Seal In Extension Housing)	1	89-Up	92698A	N/A
698I	Baffle, Differential Bearing (A604) (Under Axle Seal In Differential Retainer)	1	89-Up	32698A	N/A
VALVE BODIES					
740E	Valve Body (Premium) (A604)	1	89-95	92740-1	P72990
740E	Valve Body (Premium) (A604) Round Pin Terminal	1	96-98	92740-2	P72990B
740E	Valve Body (Premium) (A604) Spade Pin Terminal	1	98-06	92740-3	P72990C
740E	Valve Body (Premium) (A606) Round Pin Terminal	1	93-97	62740-1	P72990E
740E	Valve Body (Premium) (A606) Spade Pin Terminal	1	98-Up	62740-2	P72990D
740E	Valve Body (Premium) (42RLE)	1	03-Up	162740-1	N/A
741H	Bushing, Boost Valve (Transgo®)	1	89-Up	92741T-2	72908V
741H	Sleeve, Pressure Regulator (Sonnax)	1	89-Up	S92741P-2	N/A

ILL.	DESCRIPTION	QTY.	YEAR	PART NO.	REFERENCE NO.
VALVE BODIES (Cont.)					
741H	Valve, Solenoid Switch Oversized (requires T-F-92835-TL, T-VB-Fix)	1	89-Up	92741H-1	72978V
741H	Valve Kit, Converter Regulator	1	89-Up	92741PK	K72979
741H	Valve Plugs, Solenoid Switch.....	1	89-Up	92741-2K	K72978
741H	Valve Plugs, Solenoid Switch Oversized (requires T-92835-RM Reamer)	1	89-Up	92741-2AK	K72978S
CASES & HOUSINGS					
758D	Differential Cover, Retainer (A604)	1	89-Up	92758	72993
758D	Differential Cover, Retainer (A606) (Bolts to Case, Holds Differential In).....	1	93-Up	62758	72993E
759J	Rear Cover, Transfer Gear (1 Dimple) (A604)	1	89-E91	92759	N/A
759J	Rear Cover, Transfer Gear (2 Dimples) (A604)	1	L91-Up	92759A	72992
759J	Rear Cover (Chain Cover) (A606)	1	93-Up	62759	72992E
760D	Case, 2.5L (A604) (w/ By-Pass Valve Under Pump).....	1	89-Up	92760A	C604-1
760D	Case, 3.0L (A604) (w/o By-Pass Valve Under Pump).....	1	89-Up	92760D	C604-2
760D	Case, 3.3L (A604) (3 Bolt Top Mount, Range Sensor) (Neutral Safety Switch).....	1	96-Up	92760CC	C604-4
760D	Case, 3.3L (A604) (3 Bolt Top Mount, Range Sensor) (PRNDL Hole on top of VB)	1	98-Up	92760CD	N/A
760D	Case, 3.3L (A604) (w/ By-Pass Valve Under Pump).....	1	89-Up	92760C	C604-3
760D	Case, 3.3L (A606)	1	93-Up	62760A	N/A
760D	Case, 3.8L (A604) (3 Bolt Top Mount, Range Sensor) (Neutral Safety Switch).....	1	96-Up	92760CC	N/A
760D	Case, 3.8L (A604) (3 Bolt Top Mount, Range Sensor) (1.410" PRNDL Hole on top of VB)	1	98-Up	92760CD	N/A
760D	Case (2.4L) (42RLE).....	1	03-Up	162760	N/A
760D	Case (3.7L) (42RLE).....	1	03-Up	162760A	N/A
761D	Plug, By-Pass	1	89-Up	92761B-6	72925S
765E	Pan (A604)	1	89-Up	92765	72991
765E	Pan (A606)	1	93-Up	62765	72991E
765E	Pan (42RLE)	1	03-Up	162765	N/A
770I	Extension Housing (w/ Speed-O Hole) (A604)	1	89-92	92770	N/A
770I	Extension Housing (No Speed-O Hole) (A604)	1	93-Up	92770A	72981
770I	Extension Housing (2wd) (12 1/8" Long) (42RLE)	1	03-Up	162770	N/A
770I	Extension Housing (4wd) (7 1/8" Long) (42RLE)	1	03-Up	162770A	N/A
796J	Nut, Holds on Transfer Gear (Gray) (A604)	1	89-E91	92796-2	72921A
795J	Nut, Output Shaft (Planet) (A606)	1	93-Up	62795	72922
796J	Nut, Pinion Shaft (A606)	1	93-Up	62796	72923
SNAP RINGS					
860	Snap Ring Kit, Complete Kit.....	1	89-Up	92860K	K72601
860	Snap Ring Kit (10 Piece) UD, OD, Low Reverse Only	1	89-96	92860AK	N/A
860	Snap Ring Kit (8 Piece) UD, OD, Low Reverse Only	1	97-Up	92860BK	N/A
860G	On Top of Underdrive Pressure Plate (.070")	1	89-E90	92860	K72601
860G	On Top of Underdrive Pressure Plate (.076")	1	L90-96	92860A	72601F
860G	On Top of Underdrive Pressure Plate (.091")	1	97-Up	92860B	72601S
861G	Overdrive Clutch Pressure Plate (Bottom)	1	89-Up	92861	72601G
875B	Holds Input Clutch Retainer In.....	1	89-Up	92875	72601A
876B	Underdrive Clutch Pressure Plate (Bottom)	1	89-96	92876	72601C
877B	Holds Underdrive Spring Retainer In.....	1	89-Up	92877	72601B
882C	Front Planet to Rear Ring Gear	2	89-Up	92882	72601E
883H	Holds 2nd-4th Clutch Retainer In	1	89-Up	92883	72601P
885G	Low/ Reverse Pressure Plate (Tapered .069")	1	88-97	92885	72601Q
885H	Low/ Reverse Pressure Plate (Tapered .076")	1	98-Up	92885A	72601W
885H	Low/ Reverse Pressure Plate (Flat)	1	88-Up	92885B	72601R
891G	Overdrive Clutch Pressure Plate (Top) (.075").....	1	89-Up	92891	72601H
892G	Reverse Clutch Pressure Plate (.061")	1	89-Up	92892	72601J
892G	Reverse Clutch Pressure Plate (.071")	1	89-Up	92892A	72601K
892G	Reverse Clutch Pressure Plate (.081")	1	89-Up	92892B	72601L
892G	Reverse Clutch Pressure Plate (.090")	1	89-Up	92892C	72601M

CHRYSLER FWD A604
(40TE, 41TE - FWD, 41AE - AWD)

A606
(42LE)

42RLE
(Rwd)

ILL.	DESCRIPTION	QTY.	YEAR	PART NO.	REFERENCE NO.
MISCELLANEOUS COMPONENTS					
483	Cup Plug, Park Pawl (.375")	1	89-Up	54483A	13970
936E	Spring, Accumulator (Replaced by 92946B)	1-4	89-95	92936	72706
936E	Spring, Accumulator (Case / VB) Inner / Outer Update.....	1-4	89-Up	92946B	72706B
937E	Piston, Accumulator (Case / VB) Aluminum.....	1-4	89-Up	92937	72985
937E	Piston, Accumulator (Case / VB) Aluminum w/ Double O-Rings	1-4	89-Up	92947	72985N
937E	Piston, Accumulator (Case / VB) Kit w/ Sleeve.....	1-4	04-Up	92937BK	72985S
937E	Piston, Accumulator (Case / VB) Kit w/ Sleeve & Springs.....	1-4	04-Up	92937CK	K72985S
949E	Cover, Accumulator Low/ Reverse (Bonded) (Retros 89-Up) (All).....	1	89-Up	92949A	72532
957D	Retainer, Low/ Reverse Clutch Piston.....	1	89-03	92957	72957
957D	Retainer, Low/ Reverse Clutch Piston (w/ Bleed Orifice)	1	04-Up	92957A	72957B
957D	Retainer, Low/ Reverse Clutch Piston Oil Feed Seal	1	89-Up	92344K	72957P
960B	Retainer, Underdrive Piston (Bonded) (All)	1	89-Up	92960	72910
961B	Piston, Overdrive/Reverse (4 Lugs) (All)	1	90-Up	92961A	72941
962H	Piston, 2-4 Clutch (Bonded) (40TE).....	1	04-Up	92962A	72530A
962H	Piston, 2-4 Clutch (Bonded) (Exc 40TE).....	1	04-Up	92962B	72530
967D	Piston, Low/ Reverse Clutch.....	1	89-03	92967	K72531
967D	Piston, Low/ Reverse Clutch (Bonded) 40TE.....	1	04-Up	92967A	72531B
967D	Piston, Low/ Reverse Clutch (Bonded) 41TE.....	1	04-Up	92967B	72531
967D	Piston, Low/ Reverse (Bonded) (42RLE)	1	03-Up	162967	72531A
970B	Spring, Underdrive (All)	1	89-Up	92970	N/A
971F	Spring, Overdrive & Reverse Return.....	1	89-Up	92971	72945
977D	Spring, Low/ Reverse Return	1	89-Up	92977	72955
978H	Spring, 2nd/4th Clutch Return	1	89-Up	92978	72950
980B	Piston, Underdrive Housing (.500" Tall) (exc 40TE) (Bonded Retainer see 92960).....	1	89-Up	92980	72942
980B	Piston, Underdrive Housing (.750" Tall) (40TE) (Bonded Retainer see 92960).....	1	03-Up	92980A	72942B
Tool	Case Conversion Tool (Early Case to a Late Case) (A604).....	1	89-Up	T-6150	T-6150
Tool	Case Conversion Mount & Crankshaft Hole Adapter (A604)	1	89-Up	T-6150AB	T-6150B
Tool	Case Conversion Plugs (P-N / PRNDL) (A604)	1	89-Up	T-6150P	T-6150P
Tool	2-4 Piston Spring Compressor	1	89-Up	T-1437	T-1437
Tool	Bearing Cup and Cone Remover/Installer Kit	1	89-Up	T-1453	T-1453
Tool	Differential Bearing Preload Wrench (A606)	1	89-Up	T-3203	T-3203
Tool	Inner Differential Adjuster Wrench.....	1	89-Up	T-3201	T-3201
Tool	Input Clutch Outer Lip Seal Installer	1	89-Up	T-1430	T-1430
Tool	Low/Reverse Piston Installer	1	89-Up	T-9003	T-9003
Tool	Overdrive Reverse Reaction Plate Spring Compressor Kit.....	1	89-Up	T-1420K	T-1420K
Tool	Shaft Nut Remover / Installer (A606)	1	89-Up	T-6497	T-6497
Tool	Splined Socket Wrench	1	89-Up	T-2124	T-2124
Tool	Transfer Shaft Bearing Snap Ring Remover/Installer.....	1	89-Up	T-1435	T-1435
Tool	Underdrive Spring Retainer Seal Installer.....	1	89-Up	T-1438	T-1438
NOTES					